



*Aromat Corporation - Lighting Division*

***AID003***

***Application Guidelines  
for  
Aromat Electronic Metal Halide Ballasts-  
Outdoor Applications***

**NAiS<sup>®</sup>**

**The source ...**

**for Lighting Components and Product Design Expertise for the Luminaire Manufacturer**

For more information, call: **1-888-4-AROMAT**

Visit our Web Site: **[www.aromat.com](http://www.aromat.com)**

Initial Release 3/1/97

Rev D: 4/22/02

Rev. A 11/10/97

Rev. B 1/6/98

Rev. C 2/12/98

**Aromat Instruction Document: AID003****Application Guidelines for Electronic HID Ballasts:**  
**Outdoor Locations**

These guidelines are for NAIS electronic HID ballasts used in outdoor applications.

- 1) Select lamp lead cable and lamp holders whose ratings equal or exceed the following:
  - Lampholder Socket Rating: 4KV Pulse rated.
  - Lamp lead ratings: UL determines the lead temperature rating in their fixture evaluation; however, as a guideline the lamp lead cable shall be 18AWG 600VAC & 4kKV pulse rated or UL Style 3068 or equivalent.
  - Lead cable for input power conductors is typically UL Style 1015(18AWG, 90°C, 300VAC minimum.)
- 2) Connect all leads in accordance with the wiring diagram. See Appendix 1 for precautions to prevent mis-wiring and to eliminate grounding of lamp leads.

**NOTE: DO NOT CONNECT LAMP LEADS TO NEUTRAL OR TO ANY GROUNDED PARTS.**

- 3) Fixture Wiring:
  - Prevent any tension on all leads, connections, and terminations.
  - For conducted EMI reasons the power line voltage leads should not be twisted with the lamp leads. The fixture manufacturer should make the final determination of FCC compliance.
  - Make all connections secure to prevent any arcing due to loose or poor contacts.
- 4) Design the fixture and its packaging so the ballast and all electrical connections are not damaged during normal shipping and handling conditions.
- 5) A di-electric withstand (hipot) test should be conducted on all fixtures with a functional test conducted after the di-electric test. The voltage from leads to case shall not exceed the UL specified value. No di-electric test shall be conducted between line leads. See Appendix 1 for more information on hipot test.
- 6) Proper ballast handling is essential to ensure reliability and long trouble-free operation.
  - a. Ballast should not be altered in any fashion without the written approval from the Director of Aromat Corporation's Technical Center.
  - b. Ballast has no serviceable parts; **DO NOT OPEN THE BALLAST**. Opening of the ballast will result in a voiding of the warranty.

**Aromat Instruction Document: AID003**

- c. Ballasts that have been dropped should not be used.
- d. Ballast should not be carried by the lead wires.
- e. Ballast should not be used which have been operated in any abnormal fashion, e.g. higher line voltage than the rated range, non-rated loads, excessive withstand voltages, etc.

**7) Fixture Application Recommendations:**

- a. Read, install and operate the ballast per the usage and caution statements on the ballast nameplate, the Application Guidelines and the Manufacturing Survey. See Appendix 1.
- b. Install per local and national electrical code regulations.
- c. During any servicing of lamps or ballasts, the power must be turned off..
- d. Ballast should not be used with any dimmer or auxiliary controls without express approval by Director, Technical and Product Planning Center, Aromat Corporation.
- e. Ballast should be operated only on power sources whose voltage does not exceed  $\pm 10\%$  of the ballast rated voltage and the case hot spot temperature adheres to the maximum temperature limit.

**8) Outdoor Fixture Applications:**

Due to the high humidity in outdoor applications; the following guidelines have been established for outdoor usages:

- a. Standard products can be only used indoors and in under-eaves type applications where the FIXTURE is not exposed to the weather. (Outdoor Type I applications.)
- b. All outdoor fixtures must be weatherproof and designed to prevent water from entering the ballast housing. Any water damage or circuit failures due to water or condensing humidity found in the ballast will result in the voiding of the warranty.
- c. In outdoor “above-ground” applications, the OEM can use the standard products in weatherproof fixtures without further encapsulation. Where possible, the ballast shall be oriented so the leads-exit-end is towards the bottom of the fixture. This prevents moisture from condensing on lead wires and dripping down the leads into the case through the grommets. However, any water or circuit failures due to water damage or condensing humidity found in the ballast will result in the voiding of the warranty.
- d. For outdoor “in-ground” applications, Aromat is introducing a “sealed” ballast for OEMs who encapsulate their in-ground fixture to provide a totally waterproof ballast housing. Tests must be conducted of each OEM’s potting compound to assure the “sealed” ballast is compatible. It must be stated that no foreign material including the OEM’s potting compound shall enter the Aromat ballast due to the potential solvent

**Aromat Instruction Document: AID003**

effects on components and/or thermal performance degradation. It is the OEM's responsibility to make the ballast housing totally waterproof over the expected life of the fixture. Any water damage or circuit failures due to water or condensing humidity found in the ballast will result in the voiding of the warranty. Aromat's Technical Center can assist you in the encapsulation compatibility analysis. The ballast warranty may be voided if the above restrictions are not followed.

- e. All outdoor fixtures must be evaluated to assure that the ballast case hot spot temperature in the fixture does not exceed the specified maximum ballast temperature limits when used in the final end-use application conditions and ambient temperatures.

9) **Lamps** : The Aromat NAIS electronic ballasts are primarily designed for ceramic arc tube metal halide lamps and most lamp companies have only tested electronic ballasts on their ceramic versions. Not all metal halide lamps are compatible with electronic ballasts. **PLEASE CONSULT THE LAMP MANUFACTURER FOR RECOMMENDED LAMP TYPES.** Therefore, it is very important for the OEM to instruct and label their fixtures accordingly so the end user uses only compatible, recommended lamps. Aromat warranty will not cover the usage of non-compatible lamps.

**Aromat Instruction Document: AID003****APPENDIX 1:****OEM Manufacturing Survey Procedures**

**OBJECTIVE:** To assure our HID ballasts are assembled and tested properly without causing “lamp lead to ground” failures or nuisance “good-as -is” returns.

**BACKGROUND:** Unlike magnetic HID ballasts, electronic HID ballasts CAN NOT have the white (neutral) power lead connected to the lamp screw-shell. The output of the electronic HID ballast is “floating” from the neutral line and a ballast will fail if a blue lamp lead is connected to white or to ground. The following survey items are listed below as a guideline to survey an OEM facility to detect and eliminate this potential failure mechanism. Also, the shut-down feature must be understood by the OEMs and documented to their end users to minimize nuisance returns.

**1. ASSEMBLY LINE ITEMS:**

- a) Typically, the fixture housing has multiple wiring harnesses or groups of leads entering it. A group coming from the lampholder, a group coming from the track fitting adapter, the ballast wires and a ground wire to the housing. Assembly procedures should be checked for the possibility of connecting a blue lamp line by accident to the wrong lead: If an OEM uses the same lead types & lead colors (black, white & green) for both groups going to the adapter fitting and to the lampholder; PERHAPS by accident, a blue lead that should have been connected to the “white” lead that goes to the lampholder could be incorrectly connected to the “white” lead that goes to the adapter fitting. At power up; 120 volts would be applied from black to BLUE, damaging the unit.

**RECOMMENDATION:** Use different lead colors for output leads to lampholder as a preventive measure.

- b) Many fixture housing wiring compartments are very small after the ballast is inserted making the wiring very difficult. Due to this small volume, it is possible to have a pinched or damaged lamp lead making contact to the fixture housing or ballast case. This condition duplicates a grounded lead that will cause the ballast to fail.

**RECOMMENDATION:** Add proper tubing or tape around the lamp leads and connectors to prevent insulation damage.

**Aromat Instruction Document: AID003**

- c) Examine the fixture housing for sharp edges and “burrs” that could nick, pierce or damage the lead insulation.

RECOMMENDATION: Add proper tubing around the lamp leads to prevent insulation damage or have the metal parts de-burred.

- d) Provide for adequate insulation from the lampholder terminals to the grounded lamp socket housing. Breakdown from lamp holder contacts to ground should exceed the rated socket pulse voltage by at least ten (10) %.

RECOMMENDATION: Add insulation piece between lampholder terminals and housing.

- e) Examine lead insulation for any flexing points, especially at any lead exit locations that may damage the insulation.

RECOMMENDATION: Add tubing around the lamp leads to prevent insulation damage at the flex points; especially if a braided outer jacket is used.

- f) Check to see if the ballast can move inside the fixture housing. The ballast case edges could damage the lead insulation and create a path to ground.

RECOMMENDATION: Ballasts shall be mechanically secured inside their housing so they can not move during shipping, handling or installation. This will assist in heat transfer and will eliminate the possibility of lead damage when shipping to the end user, thereby, eliminating any field failures.

- g) Conduct HIPOT test or continuity test to the fixture BEFORE applying line voltage to the ballast. The HIPOT test is typically conducted by connecting together the lampholder screw-shell and center contacts and the track adapter line connections (black & white only; do not include ground contact on adapter). A special connection setup is necessary. A dielectric Hipot tester is then used to apply 1500VAC between the common connection & the fixture housing. If the wiring was correct, there will be no “dielectric breakdown” indication. If a lead was pinched or damaged, the Hipot tester will indicate breakdown and the fixture wiring should be examined for the cause. If damage points or pinch point are noted, additional insulation or lead sleeving may be necessary for the OEM to add to the fixture. See Table 1 for recommended testing on electronic ballasted fixtures.

## Aromat Instruction Document: AID003

- h) Any wiring terminals or connectors must be capable of withstanding the ignition voltage potentials.

RECOMMENDATION: Consult with connector vendor to assure ratings are sufficient.

- i) Assembly work surfaces should not utilize materials (felt, fabric, carpet, etc) that may generate static electricity. Under worst case conditions, large static discharge voltages could damage the ballast.

RECOMMENDATION: Use anti-static work surfaces for fixture assembly areas.

**2. MANUFACTURING TEST EQUIPMENT:** See Table 1 for full testing recommendations.

- a) **ELECTRICAL TESTING:** Any electrical testing on the production line must be examined to assure that no connections between the “white” power lead and the blue lamp leads are made by the test setup or test machine. Since magnetic ballasts make this connection; the following questions must answered:
  - Does a different test setup have to be made for electronic ballasts?
  - How is this assured before any electronic ballast is powered up?
- b) **METER CONNECTIONS:** Any test instrumentation such as oscilloscopes, voltmeters, power-meters etc. that are connected to the lamp leads must not provide a connection to ground(neutral). These instruments must use isolation transformers to “float” probes and test leads from ground so the ballast will not be damaged. (See Figure 1).

**CAUTION:** The output of the ballast has a 4000 V ignition pulse during open circuit conditions. Protection for the safety of personnel and for any meters or instrumentation must be provided!

### **3. LABORATORY TESTING:**

- a) **LABORATORY TESTS:** Any laboratory electrical testing must follow the same “isolation” procedures as stated above. (See Figure 1.)
- b) **ISOLATION FROM GROUND:** Please remember than ALL test equipment must be floated including oscilloscopes and any plotter or printer that may be connected to it! It is also advised to

## **Aromat Instruction Document: AID003**

only connect one instrument at a time to prevent measurement interactions. As an alternative, the input to the ballast can be isolated if laboratory rules prevent instrument isolation.

- c) **THERMAL TESTS:** All thermal testing of any ballast components must be done with extra care. The insulation on most thermocouples is relatively low compared to the voltages inside an HID electronic ballast. If thermocouples are attached to “live” parts (e.g. electrolytic capacitors) they should be first insulated from the part with a thin insulation (mylar, etc.) piece. This will prevent the thermocouple from completing a “short circuit” if

the thermocouple lead insulation is damaged causing one of the thermocouple conductors to contact the ballast enclosure or fixture housing(ground). For dual protection it is advised to also isolate the temperature measuring instrument from ground with an isolation transformer. (See Figures 2 & 3).

### **4. TESTS WITH METAL HALIDE LAMPS:**

- A) **TESTING WITH LAMPS:** If a metal halide lamp is used to test the ballasts, it must be understood that with repeated starts the lamps will get hot and will not start. This is not a ballast problem, but a lamp hot restrike reignition issue. When the lamps cool down, they will then restart. Use an assortment of lamps so each one has time to cool down before being reused.

### **5. BALLAST SHUT-DOWN FEATURE:**

- a) **30 MINUTE SHUT-DOWN:** If any long term ballast testing is conducted, please be aware that our ballast has a shut-down feature that will turn-off the output of the ballast if the lamp fails to start in approximately 30 minutes. Therefore, if a lamp at end-of-life fails to start, this shut-down function will occur. To re-lamp; the power to the fixture should be turned off, new lamps installed, and the power turned back on. This switching-off of the input power resets the ballast circuitry to initiate the starting sequence again.
- b) **POWER RESET:** To re-emphasize, the ballast output is reset only when the input power is turned off and then back on. Therefore, if a lamp is off the ballast function can be checked by replacing the old MH lamp with a known good MH lamp; turn off the power to the ballast and retry.
- c) **OEM INSTRUCTIONS:** This feature should be explained to the end-user in the OEM literature and if possible on the fixture.

**Aromat Instruction Document: AID003**

**Figure 1: Electrical Measurement Diagram**

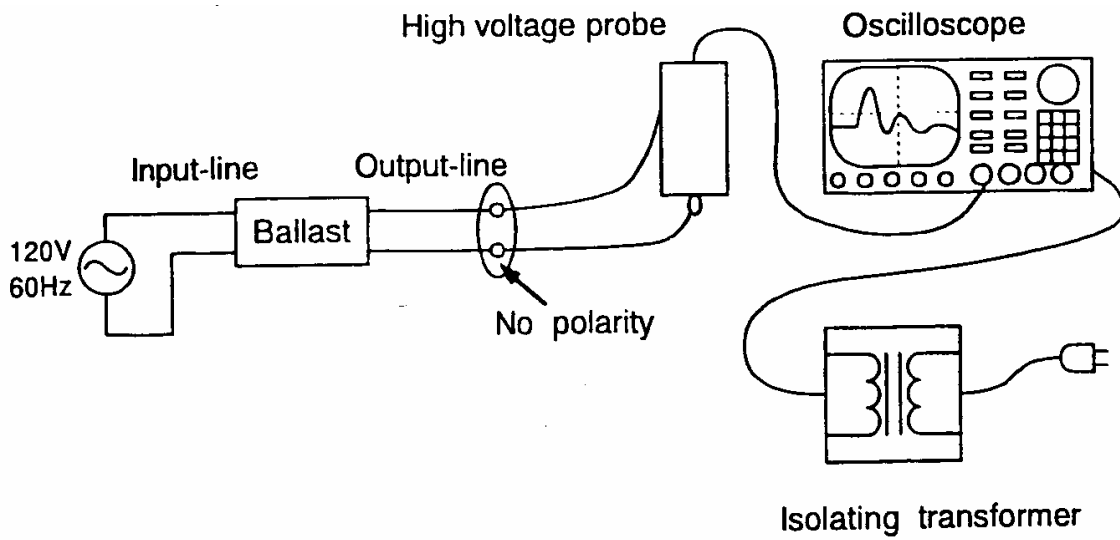

**Figure 2: Thermal Measurements**

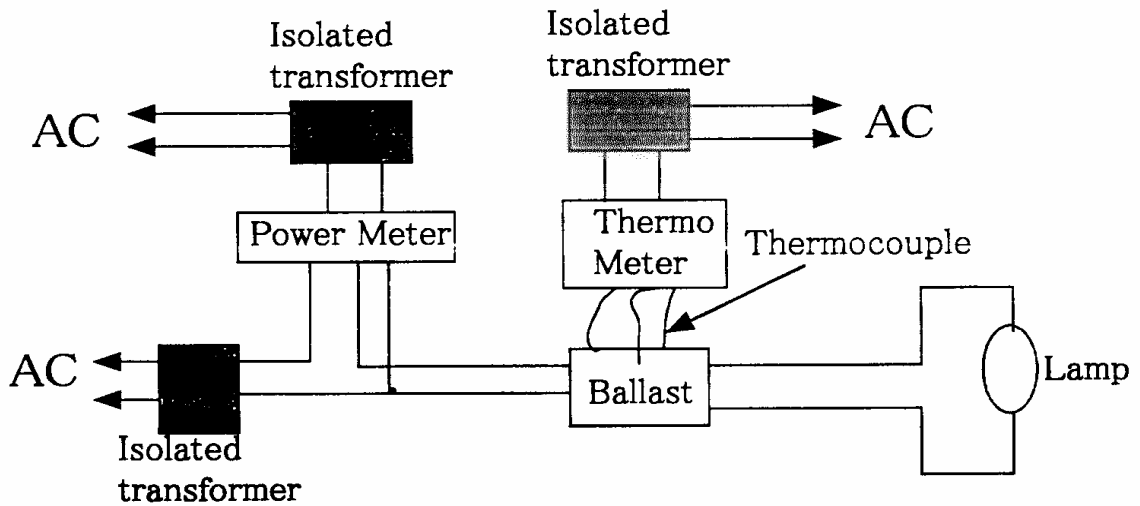
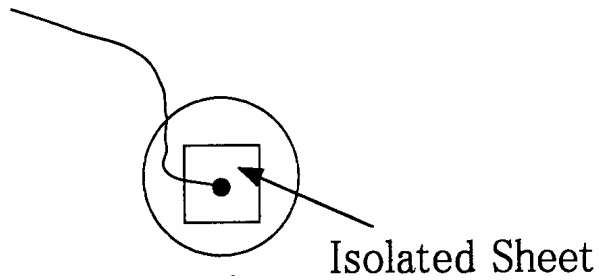

**Figure 3: Thermocouple Connection For Live Parts**

Initial Release 3/1/97  
Rev. A 11/10/97  
Rev. B 1/6/98  
Rev. C 2/12/98

Rev D: 4/22/02

## Aromat Instruction Document: AID003



**TABLE 1**

### RECOMMENDED TESTING ON AROMAT BALLASTS

SEQUENCE	PURPOSE	PROCEDURE
<b>1</b>	<p>HIPOT :</p> <p>To detect any "shorts-to-ground" that would fail the ballast</p>	<ul style="list-style-type: none"> <li>• After fixture assembly &amp; <b><i>before</i></b> any power is applied to the input of the ballast, conduct hipot (dielectric withstand) test.</li> <li>• Connect input &amp; output leads/terminations together with use of appropriate connectors &amp; lampholder probes.</li> <li>• Apply up to 1500VAC hipot between common connection of terminations and fixture ground.</li> <li>• Control the hipot time to a 1 second minimum &amp; 3 sec. maximum.</li> <li>• Short circuit hipot current should be 10ma maximum.</li> <li>• Normal capacitive &amp; leakage hipot current is approximately 2 ma. Hipot failure indication must use trip current greater then 2 ma. (This limit may need to be determined empirically after running many units as it depends on the leakage of the test gear.</li> <li>• If a hipot failure is indicated, <b>STOP TEST &amp; CORRECT DEFECT! Do not apply power to the ballast until the defect is fixed.</b></li> </ul>
<b>2</b>	<p>LAMP TEST:</p> <p>To determine if the total fixture wiring and ballast are proper &amp; functional.</p>	<ul style="list-style-type: none"> <li>• Insert proper wattage MH lamp into the lampholder.</li> <li>• Apply proper input voltage to the fixture.</li> <li>• Visually watch lamp start (Note: Multiple lamps should be used to prevent hot lamp re-strike problems).</li> </ul>

**Aromat Instruction Document: AID003**

Initial Release 3/1/97  
Rev. A 11/10/97  
Rev. B 1/6/98  
Rev. C 2/12/98

Rev D: 4/22/02

## Aromat Instruction Document: AID003

### Revision Summary:

Rev A	<p>Issued Main Text:</p> <ul style="list-style-type: none"> <li>2) Added note referring to new Appendix 1</li> <li>3) Eliminate phrase on keeping leads far apart</li> <li>4) Added note to see Appendix 1</li> <li>7a) Added Reference to Application Guidelines and Appendix 1</li> <li>7e) Revise power source wording</li> <li>8) Added Outdoor Application section</li> <li>9) Added new compatibility verbiage</li> </ul> <p>Appendix 1 added</p>
Rev B	<p>Main Text:</p> <ul style="list-style-type: none"> <li>Changed title to AID001 &amp; modified format</li> <li>8) Removed body of text and referred to new AID003 for outdoor application guidelines</li> <li>9) Added more detailed compatibility statements</li> </ul> <p>Appendix 1:</p> <ul style="list-style-type: none"> <li>1.g) Added note to see Table 1; also eliminated the resistance test as an alternative to the hipot test.</li> </ul> <p>Table 1: New Revision sheet: New</p>
Rev C	<p>Main Text:</p> <ul style="list-style-type: none"> <li>1) Added Note regarding input power lead cable</li> <li>3) Reinserted sentence that was deleted during reformatting regarding FCC compliance tests by OEM.</li> </ul> <p>Appendix 1:</p> <ul style="list-style-type: none"> <li>1. d) Change “twenty” to “ten”</li> <li>1. i) Added “anti-static” statement</li> <li>2. b) Added Caution note for safety.</li> <li>3. b) Added sentence for alternative of floating the ballast.</li> </ul>
Rev D	<p>Main Text: Updated outdoor usage for in ground fixtures to use “sealed” ballast</p>

Initial Release 3/1/97  
 Rev. A 11/10/97  
 Rev. B 1/6/98  
 Rev. C 2/12/98

Rev D: 4/22/02