

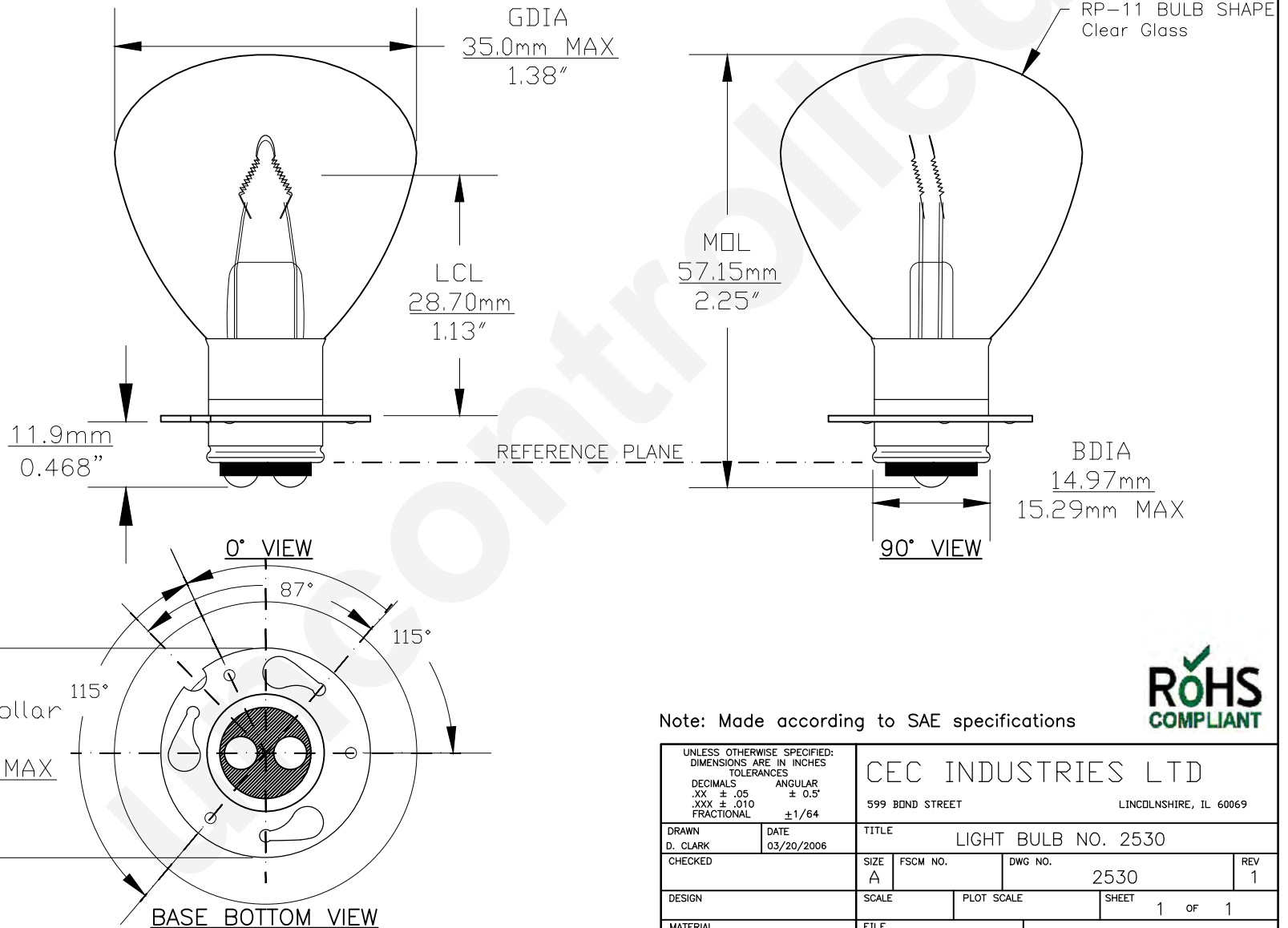

Since 1959

PART NO.	BASE TYPE	DESIGN VOLTS	DESIGN AMPS	MSCD	FILAMENT TYPE	AVERAGE LIFE HOURS	REVISIONS			
							REV #	DESCRIPTION	DATE	APPROVED
2330	D.C. Prefocus A (P15d30A)	5.9V 6.2V	6.53±15% 4.23±15%	50±30% 32±30%	C-2V C-2V	200 200	1	ISSUED	03/20/2006	D.C.
							2	REDRAWN FOR ADDITIONAL DIMENSIONS	11/06/2014	R.M.



Note: Made according to SAE specifications



UNLESS OTHERWISE SPECIFIED: DIMENSIONS ARE IN INCHES TOLERANCES		CEC INDUSTRIES LTD			
DECIMALS .XX ± .05 .XXX ± .010	ANGULAR ± 0.5°	599 BOND STREET		LINCOLNSHIRE, IL 60069	
FRACTIONAL ± 1/64		TITLE LIGHT BULB NO. 2530			
DRAWN D. CLARK	DATE 03/20/2006	SIZE A	FSCM NO.	DWG NO. 2530	REV 1
CHECKED		SCALE	PLOT SCALE	SHEET 1 OF 1	
DESIGN		FILE 2530.pdf	DRAWING NOT TO SCALE		