

SPECIFICATION

PRODUCT ITEM : BALED60P-42XXX(XXX=115 thru 150)

SPECIFICATIONS: 27-42V/1150-1500mA

EDITION: 1.0

Outline Drawing

Outline size: L156.1*W54.1*H29.8mm

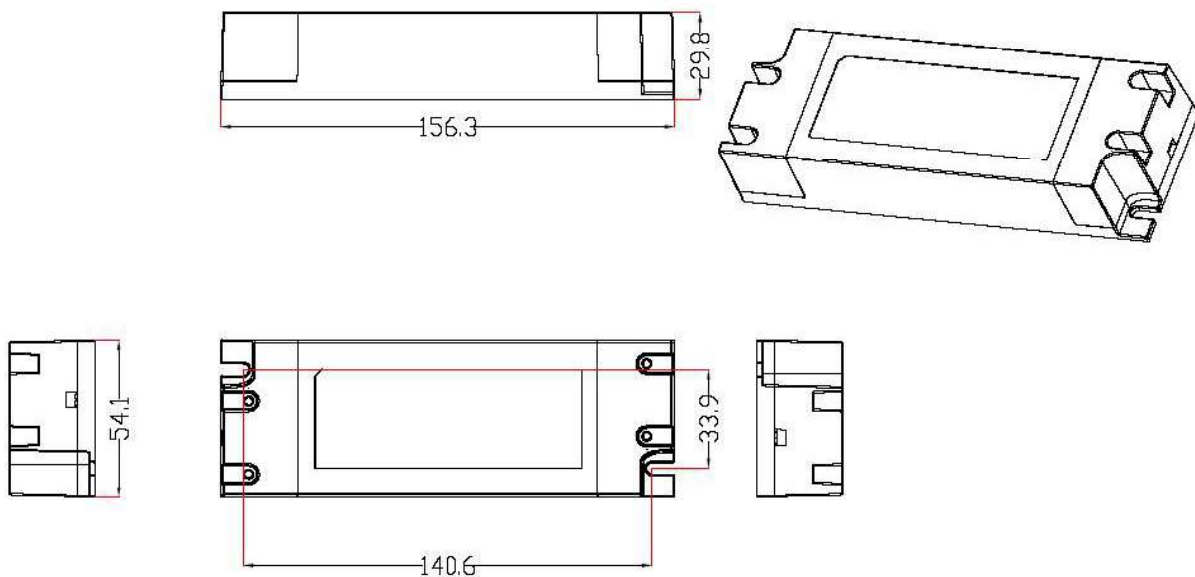

1. SCOPE

The document detail the electrical, 0 to 10V dimming performance, mechanical , and environmental specifications of a 63W constant current LED driver. This LED drive power supply is suitable only for LED load.

2. Input Characteristics

2.1. Input Voltage & Frequency

The range of input voltage is from 90 to 305Vac single phase.

Input Characteristics	Minimum	Nominal	Maximu
Input Voltage	90Vac	100-277Vac	305Vac
Input Frequency	47Hz	60Hz/50Hz	63 Hz

2.2. Input AC Current

0.75A max. @ input 100Vac & max. load

2.3. Inrush Current

50A max. @ input 277Vac & max. load

2.4. Power Factor

0.9 min. @ input 110Vac & max. load

0.9 min. @ input 220Vac & max. load

2.5. Efficiency (Normal)

88% min. @ input 110Vac & max. load / 89% min. @ input 220Vac & max. load

3. Output Characteristics

3.1. Static Output Characteristics <Vo & R+N>

Output	LED Load		Output voltage Range	R+N
	Min. Load	Max. Load		
Output current	40.5W	63W	27-42Vdc	≤6Vp-p

Ripple & Noise: Measurement is done by 20MHz bandwidth oscilloscope and the output paralleled a 0.1uF ceramic capacitor and a 10uF electrolysis capacitor. (test under the condition of rated input and rated output)

3.2. Turn - on Delay Tim

0.5S max. @ input 100 - 277 Vac & max. load

4. Protection Requirements

4.1. Short Circuit Protection

The input power shall decrease when the output rail short, the power supply shall no damage, and shall be self-recovery when the fault condition is removed

4.2. LED disconnection Protection /LED

When the LED disconnection the product is protected such as hiccup or when it is at the highest point of output voltage the product would not be hurted when the fault is excluded or is start working again the power supply is working normally.

5. Environment Requirements

6. 5.1. Operating Temperature and Relative Humidity

7. 0°C to +55°C

20%RH to 90%RH

5.2. Storage Temperature and Relative Humidity

-30°C to +70°C

10% to 90%RH non-condensing @ Sea level shall be low 10,000 feet.

5.3. RoHS

The LED driver shall meet the RoHS requirement.

6. Reliability Requirements

6.1. Burn-in

The power supply shall under go a minimum of 2-4 Hours burn-in test at $40^{\circ}\text{C} \pm 5^{\circ}\text{C}$ under full load condition

6.2. MTBF Qualification

The MTBF shall be at least 20,000hours at 25°C , Full load and nominal input condition

7. Safety Standard

7.1 Dielectric Strength(Hi-pot)

Primary to Secondary: 3750Vac 5mA Max / 60second(3second for production)

7.2 Insulation Resistance

50M Ω min. at primary to secondary add 500Vdc test voltage.

7.3 EMI Standard

EN 55015:1998,+A1:2000 +A2:2003,CLASS B.