

BDS-600 series

Low Voltage Dual-Tech Occupancy Sensor



OVERVIEW

The BDS-600 series member of the TRANS family is a low voltage dual-tech occupancy sensor designed for energy efficient lighting control. This sensor combines digital Passive Infrared (PIR) and state-of-the-art High Frequency Doppler (HFD) sensing technologies into an aesthetically pleasing, installer friendly, low profile housing to provide second-to-none occupancy sensing performance for today's sustainable buildings.

The sensor provides an isolated dry contact output for load switching through a Power Pack or a Building Management System. In addition, the sensor employs a digital ambient light sensor to inhibit the output when ambient light level is higher than the threshold set. Accu-Set potentiometers make delay time and lux level settings fast, easy and accurate. Numerous types of lens can be applied to offer different PIR sensing ranges required for all applications. The sensitivity of HFD sensor can be adjusted if necessary.

The sensor comes with color coded wires for direct wiring connection. A unique mounting bracket with snap-on clip makes the sensor installation an easy job. With the BDS-600 series sensor, you can easily deliver an occupancy sensing based lighting/HVAC control to all applications.

FEATURES

- Omni-directional digital quad element PIR sensor
- Advanced High Frequency Doppler module
- Digital data control ambient light sensor built-in
- 12~24VDC low voltage power supply operation
- Isolated dry contact output for versatile control
- Accu-Set potentiometer TIME and LUX settings
- Bi-color LED indicator for walk test verification
- Available with interchangeable lens selection
- Snap-on clip makes sensor installation easy

APPLICATION

The BDS-600 occupancy sensor can be used to control area lighting or HVAC with an IR-TEC power pack or in connection with building management systems. Various control modes can be achieved by different wiring connections. Consult with an IR-TEC team member for the assistance of more complex controls.

- Lighting Control
- HVAC Control
- Building Management

OPERATIONS

With 12-24 VDC power supplied, the BDS-600 will activate its output when PIR sensor detects the presence of occupant. The delay time starts and HFD sensor will start operating to detect minor motion within the range. The output will be continuously engaged if PIR or HFD detects the motion of occupant. The sensor output can be set to inhibit when ambient light level is higher than the threshold. Sensor will disengage the output if no motion is detected before the delay time elapses.

Lens Options

Different lens options can be applied to provide different coverage at different mounting heights (H). When adding the lens code on the sensor model number, the lens is then automatically shipped with the sensor.

| | Lens | Shape | Mounting Height | | Coverage |
|---|------------|-------|-----------------|-----------|-----------|
| A | Standard | Cone | 8~15 ft. | 2.4~4.5m | 2X height |
| B | Extra wide | Cone | 8~10 ft. | 2.4~3.0m | 6X height |
| C | High bay | Cone | 15~30 ft. | 4.5~9.0m | 3X height |
| D | Standard | Round | 8~20 ft. | 2.4~6.0m | 2X height |
| F | Extra wide | Dome | 8~20 ft. | 2.4~6.0m | 4X height |
| G | Aisle way | Arch | 8~40 ft. | 2.4~12.0m | 3X height |

DETECTION PATTERN

Top View

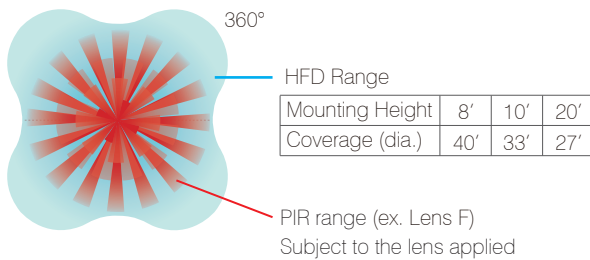

Side View

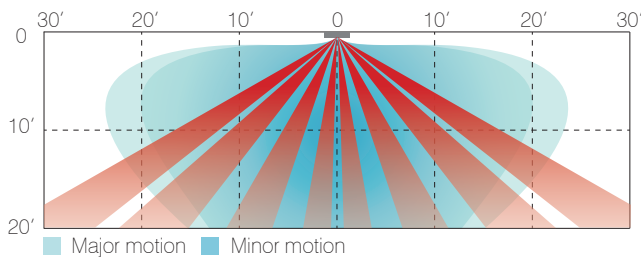

Wiring Diagram

A. Building Management System control

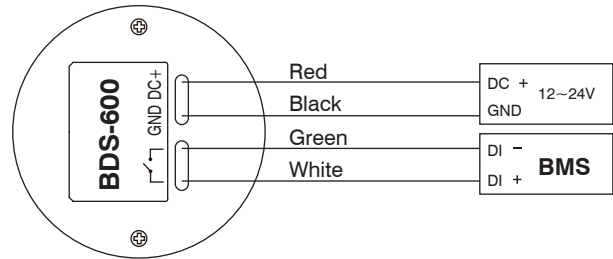

B. Power Pack control

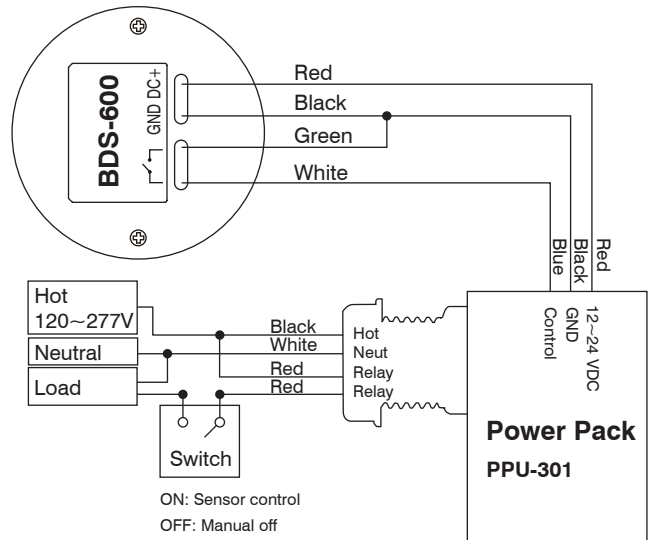

SPECIFICATIONS

| | |
|---------------------|--|
| Power supply | 12~24 VDC±5 |
| Current drain | 20/45 mA@24VDC, vacant/occupied |
| Motion sensor | Digital PIR & High Frequency Doppler |
| Light sensor | Digital, color temperature compensation |
| Control output | Form A relay, NO, dry contact |
| Contact rating | 30VDC, 2.0A max. isolated |
| Detectable speed | 0.5~10 ft./sec. (0.15~3 m/sec) |
| Mounting height | 8~20 ft. (2.4~6 m) |
| Detection range | Subject to the lens applied and height |
| Delay time | T/1/3/5/10/20/30 min. T:10 sec. for test |
| Ambient light level | 5/10/30/50/100/200/24H lux & disabled |
| HFD sensitivity | 40~100% adjustable |
| Op. humidity | Max. 95% RH |
| Op. temperature | 14°F~122°F (-10°C~50°C) |
| Dimensions | Ø4.33"x H1.0" (Ø110 x H25mm) |

TRANS PIR Occupancy Sensor LENS DATASHEET

OVERVIEW





All TRANS PIR based Occupancy Sensors feature with interchangeable lens options. Each lens provides different sensing coverage which varies with the actual mounting height.

The specified detection coverage and mounting height of each lens are based on the test result of human motion walking across the detection zones. The actual coverage may be reduced if the motion is moving toward or away the sensor. High ambient temperature (above 82°F/28°C) could reduce the coverage of PIR sensor. If ambient temperature at the covered area are expected to be high sometimes, consider adding more sensors or reduce the mounting height, if possible.

The followings are all available lens options and their respective detection patterns at printing time. For details of latest lens options available, please visit www.irtec.com.



LENS OPTIONS

| Lens | | Shape | Recommended Mounting Height | | Coverage |
|------|---|------------|-----------------------------|-----------------------|-----------|
| A |  | Standard | Cone | 8~15 ft. 2.4~4.5m | 2X height |
| B |  | Extra wide | Cone | 8~10 ft. 2.4~3.0m | 6X height |
| C |  | High bay | Cone | 15~30 ft. 4.5~9.0m | 3X height |
| D |  | Standard | Round flat | 8~20 ft. 2.4~6.0m | 2X height |
| F |  | Extra wide | Dome | 8~20 ft. 2.4~6.0m | 4X height |
| G |  | Aisle way | Arch | 8~40 ft. 2.4~12.0m | 3X height |

NOTE:

- Lens G can be rotated to change the direction of coverage. Its 3X height coverage refers only to the total length, the width of coverage will vary with the mounting height (see table of Lens G section). This lens is not IP-66 rated.
- Lens C/G may be mounted up to 40/50 ft. (12/15m) or higher at the area, providing with large moving object such as forklift trucks. Before installing all sensors, please ensure that the sensor can have optimal detection at desired height.

LENS A 2X Standard

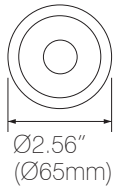
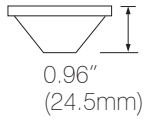

Top View

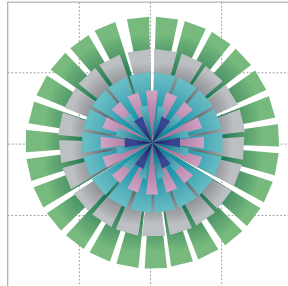

| | | | | | |
|------------------------|---------|----------|----------|----------|----------|
| Mounting Height | ft. (m) | 8 (2.4) | 10 (3.0) | 12 (3.6) | 15 (4.5) |
| Max. Coverage Diameter | ft. (m) | 16 (4.8) | 20 (6.0) | 24 (7.2) | 30 (9.0) |

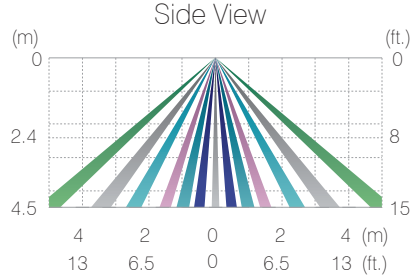

LENS B 6X Extra wide

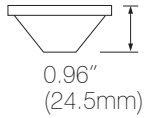

Top View

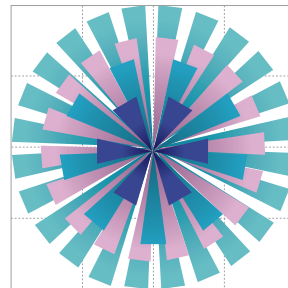

| | | | | | |
|------------------------|---------|-----------|-----------|-----------|-----------|
| Mounting Height | ft. (m) | 8 (2.4) | 8.5 (2.6) | 9 (2.8) | 10 (3.0) |
| Max. Coverage Diameter | m (ft.) | 48 (14.4) | 51 (15.6) | 54 (16.8) | 60 (18.0) |

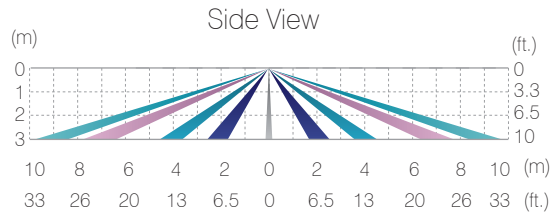

LENS C 3X High bay

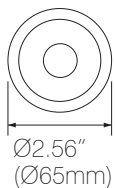
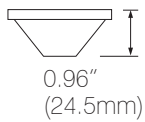

Top View

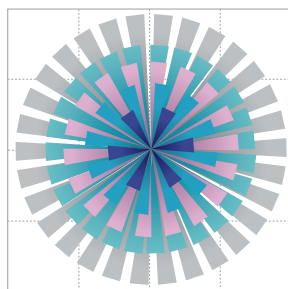

| | | | | | |
|------------------------|---------|-----------|-----------|-----------|-----------|
| Mounting Height | ft. (m) | 15 (4.5) | 20 (6.0) | 26 (8.0) | 30 (9.0) |
| Max. Coverage Diameter | ft. (m) | 45 (13.5) | 60 (18.0) | 78 (24.0) | 90 (27.0) |

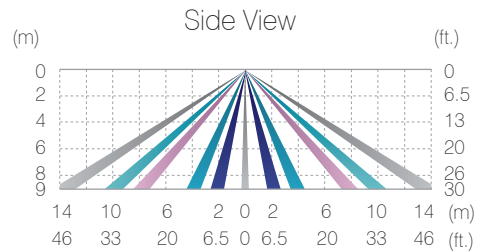

LENS DATASHEET

TRANS

LENS D 2X Standard

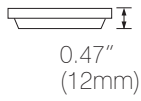

Top View

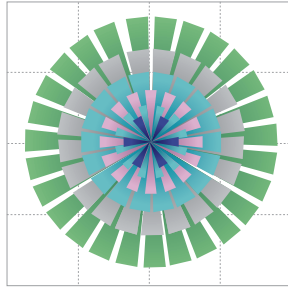

| | | | | | |
|------------------------|---------|----------|----------|----------|-----------|
| Mounting Height | ft. (m) | 8 (2.4) | 10 (3.0) | 15 (4.5) | 20 (6.0) |
| Max. Coverage Diameter | ft. (m) | 16 (4.8) | 20 (6.0) | 30 (9.0) | 40 (12.0) |

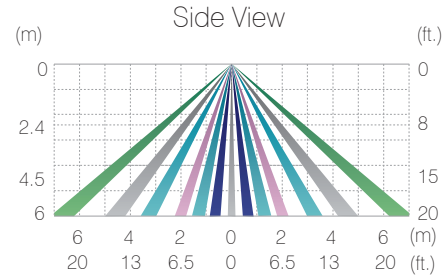

LENS F 4X Extra wide

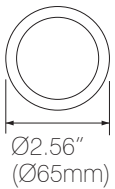
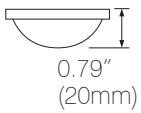

Top View

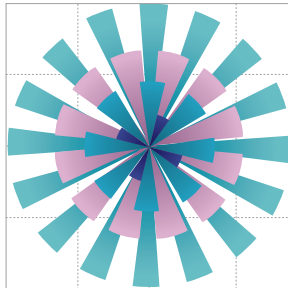

| | | | | | |
|------------------------|---------|----------|-----------|-----------|-----------|
| Mounting Height | ft. (m) | 8 (2.4) | 10 (3.0) | 15 (4.5) | 20 (6.0) |
| Max. Coverage Diameter | ft. (m) | 32 (9.6) | 40 (12.0) | 60 (18.0) | 80 (24.0) |

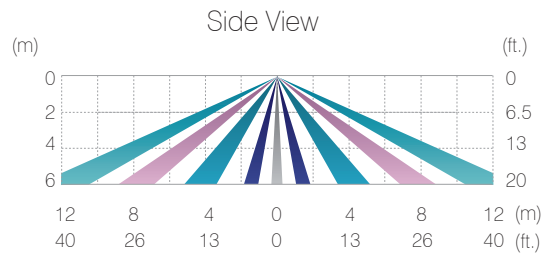

LENS G 3X Aisle way

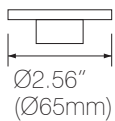
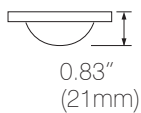

Top View

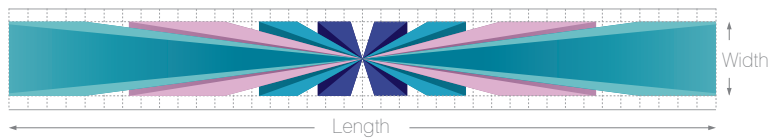

| | | | | | |
|------------------------------|---------|--------------------|---------------------|--------------------|---------------------|
| Mounting Height | ft. (m) | 10 (3.0) | 20 (6.0) | 30 (9.0) | 40 (12.0) |
| Max. Coverage Length x Width | ft. (m) | 30 x 3.3 (9.0 x 1) | 60 x 6.5 (18.0 x 2) | 90 x 10 (27.0 x 3) | 120 x 13 (36.0 x 4) |

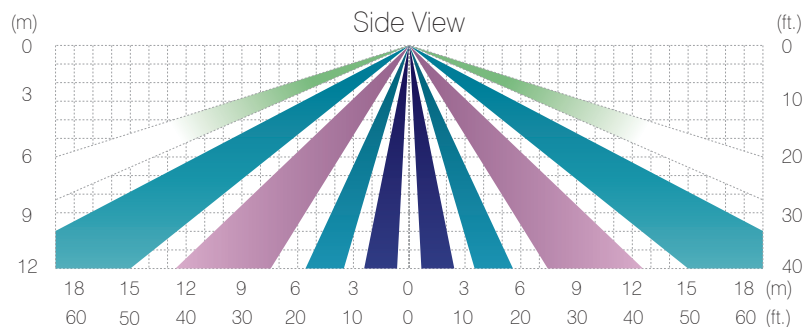

ACCESSORIES

LENS HOOD LH-110

The LH-110 is designed for bi-level control sensors to prevent its ambient light sensor from being saturated by the excessive lighting nearby.

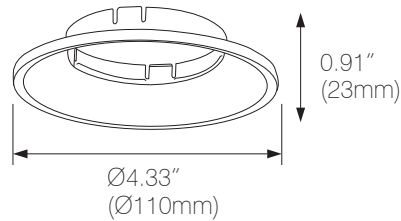

1

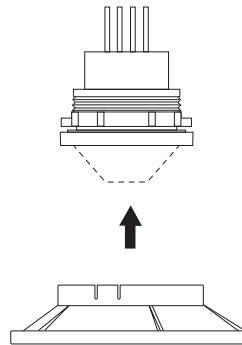

2

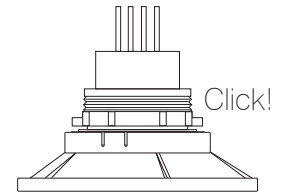

LENS MASK

LM-12C For Lens A/B/C

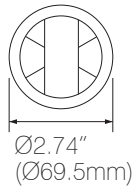
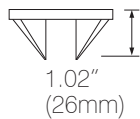

LM-12D For Lens F

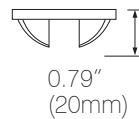

① Push the mask onto the installed lens

1

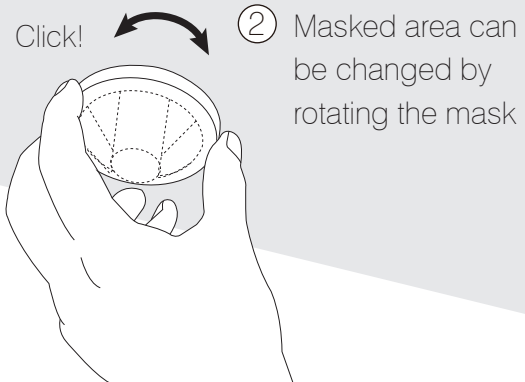

Example: Lens F with LM-12D

Top View

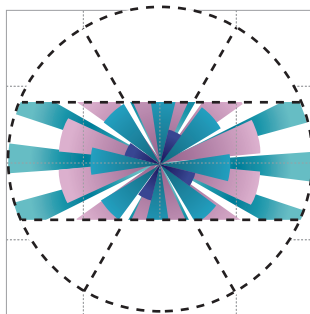

If necessary, the masked area can be altered by cutting off the respective grooved segments with a wire cutter or knife.

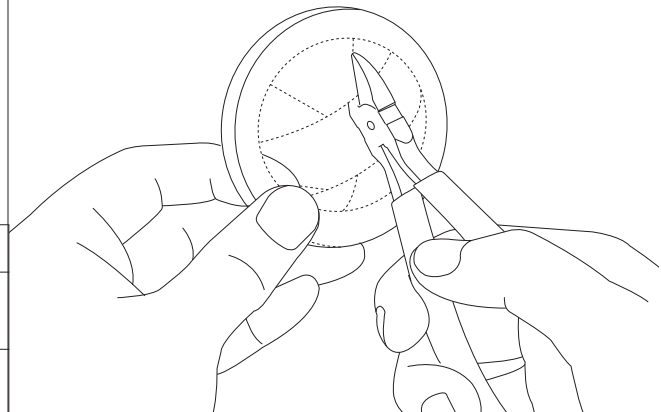

Coverage Area with Lens F and Mask

| | | | | | |
|------------------------------|---------|--------------------|---------------------|--------------------|--------------------|
| Mounting Height | ft. (m) | 8 (2.4) | 10 (3.0) | 15 (4.5) | 20 (6.0) |
| Max. Coverage Length x Width | ft. (m) | 32 x 3.3 (9.6 x 1) | 40 x 6.5 (12.0 x 2) | 60 x 10 (18.0 x 3) | 80 x 13 (24.0 x 4) |