

BOS-515 series

Low Voltage Occupancy Sensor



OVERVIEW

The BOS-515 series member of the TRANS family is a low voltage occupancy sensor designed to signal the occupancy status for area lighting or HVAC control for energy efficient building management systems.

This occupancy sensor employs a cutting edge quad element pyroelectric infrared sensor to provide omni-directional sensing capability of the occupants presence and movements. The Accu-Set digital potentiometer makes the sensor setting work easier, faster and more accurate than conventional analog potentiometers.

Like all sensors in the TRANS family, the BOS-515 series is available with various mounting options and interchangeable lenses. This provides a second-to-none design and complete installation flexibility. The sensor is designed to operate in the coldest of environments, down to -40°F/°C.

The BOS-515 series comes with an optional ambient light sensor (ALS) to inhibit the lighting if ambient light levels are higher than required. The BOS-515 is designed to provide complete occupancy sensing for automatic lighting/HVAC control, ease of use, and the simplest installation.

FEATURES

- Omni-directional quad element infrared sensor
- 12~24VAC/DC low voltage power supply
- Normally open dry contact relay signal output
- Accu-Set digital potentiometer sensor settings
- Walk test and sensing status LED indicator
- Push-in wire locking terminals for easy wiring
- Available with or without photocell sensor
- Available with variety of mounting options
- Available with interchangeable lens options

APPLICATION

- Light Control
- HVAC Control
- Building Management

The BOS-515 series can be used to control area lighting or HVAC with an IR-TEC power pack or in connection with building management systems. Various control modes can be achieved by different wiring connections. Basic wiring diagrams are included. Consult with an IR-TEC team member if a more complex wiring diagram is required.

BOS-515 series

Low Voltage Occupancy Sensor

TRANS

Auxiliary Options

BOS-515Sxx – Ambient light sensor integrated
 BOS-515Nxx – No ambient light sensor integrated

Mounting Options

The BOS-515xx series can be mounted on the ceiling or attached to a fixture by combining a specific mounting bracket (if applicable) from the chart below. The bracket will be shipped with the sensor when ordered with the respective code. Codes F and W allow the BOS-515xx to be directly integrated with OEM light fixtures in any environment.

Code	Mounting Option	Mounting Bracket
F	Fixture Integrated	---
W*	IP-66 Fixture Integrated	---
E	Fixture External	EMB-500
P*	IP-66 Fixture External	PMB-500
S	Ceiling Surface	SMB-500
C	Junction Box	CMB-500
R	Ceiling Recess	RMB-500

*Available for IP-66 fixture integration

Lens Options

The BOS-515xx series is available with the following lens options which provide different coverage at different mounting heights (H). When adding the lens code, the lens is then automatically shipped with the sensor.

Lens	Shape	Mounting Height	Coverage
A	Standard	Cone 8~15 ft. 2.4~4.5m	2X height
B	Extra wide	Cone 8~10 ft. 2.4~3.0m	6X height
C	High bay	Cone 15~30 ft. 4.5~9.0m	3X height
D	Standard	Round 8~20 ft. 2.4~6.0m	2X height
F	Extra wide	Dome 8~20 ft. 2.4~6.0m	4X height
G	Aisle way	Arch 8~40 ft. 2.4~12.0m	3X height

Example: BOS-515NWA

This sensor would come with no ambient light sensor and lens with standard detection for wet location control. Specific mounting bracket or lens may be order separately if needed. For help selecting sensors with proper mounting and lens options, please visit www.irtec.com, send your inquiry to info@irtec.com or contact an IR-TEC team member directly.

Wiring Diagram

A. Building Management System control

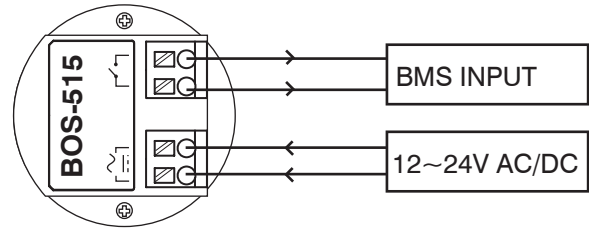

B. Power Pack control

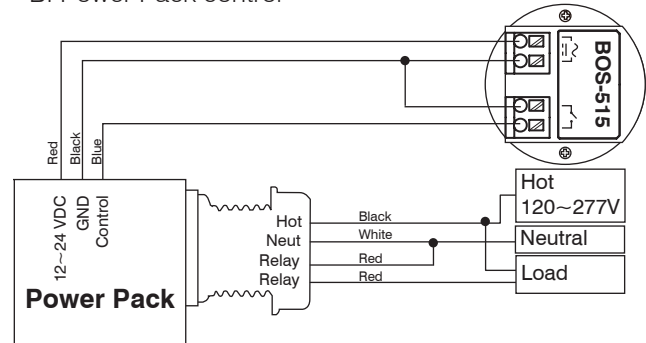

BOS-515S Front



BOS-515N Front



Sensor Back

SPECIFICATIONS

Power supply	12~24VAC/DC ± 10%
Current drain	10/20mA, 24VDC @ vacant/occupied
Signal output	Form A relay, NO, dry contact
Infrared sensor	Omni-directional quad element pyroelectric
Detectable speed	1~10 ft./sec. (0.3~3m/sec)
Mounting height	Subject to the lens type applied
Detection range	Subject to the lens applied and height
ALS setting	BOS-515Sxx: 24Hr/ 5/10/30/50/100/200 lux*
ON delay setting	BOS-515Nxx: 0/5"/10"/15"/30"/1'/2'
OFF delay setting	T/1'/3'/5'/10'/20'/30', T=2 sec. for testing
Op. humidity	Max. 95% RH
Op. temperature	-40°F~131°F (-40°C~55°C)
Dimensions	Ø2.36"x H1.45" (Ø60 x H37mm)

*10 lux equals to approximately 1 ft. candle

MOUNTING OPTIONS

OVERVIEW

Each member of IR-TEC's TRANS sensor family is available with multiple mounting options with or without a mounting bracket. These mounting options allow the sensor to be integrated with lighting fixture or mounted on the ceiling in various ways. All applicable sensors can be supplied in specific mounting option as ordered with the respective code.

Sensor Product Code



Mounting Option	Code	Bracket Model
Fixture Integrated	F	---
IP-66 Fixture Integrated	W	---
Fixture External	E	EMB-500
IP-66 Fixture External	P	PMB-500
Ceiling Surface	S	SMB-500
Junction Box	C	CMB-500
Ceiling Recess*	R	RMB-500
Fixture Internal	I	IMB-500

*Line voltage sensors not applicable

F/W-mount Sensor

Fixture Integrated

The sensors in **F** and **W**-mount are original form factor of TRANS family. Both options can be directly integrated with OEM lighting fixture through a 2" (51mm) diameter hole.





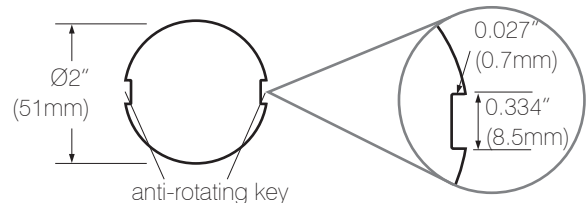





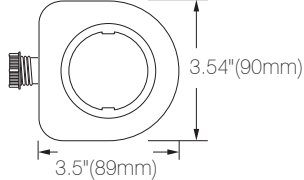

For IP-66 fixture integration, ensure to place the rubber gasket of **W**-mount sensor in between the fixture enclosure and sensor unit. Apply proper torque (0.3 lb-ft) to tighten the plastic screw nut while assemble the sensor.

Assembly Hole

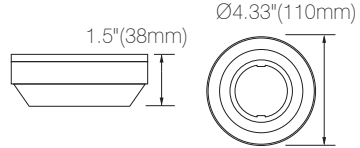

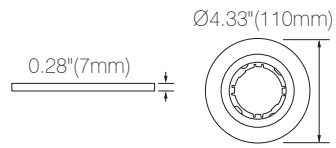

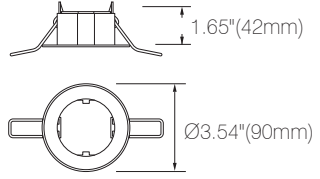
Occupancy sensor - PIR	Occupancy sensor - HFD	Daylight sensor

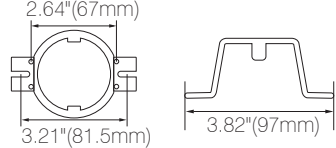
Mounting Brackets

Bracket	Code	Description	Dimensions
 EMB-500 	E	Fixture External The EMB-500 is a mounting bracket for mounting the sensor with indoor lighting fixture through a 1/2" knockout hole.	
 PMB-500 	P	IP-66 Fixture External The PMB-500 is a mounting bracket for mounting the sensor with IP-66 lighting fixtures or outdoor pole mount through a 1/2" knockout hole.	
 SMB-500 	S	Ceiling Surface The SMB-500 is a mounting bracket designed to mount the sensor on the surface of hard lid ceiling with or without junction box. Mounting on the surface of lighting fixture is also available.	
 CMB-500 	C	Junction Box The CMB-500 is a ceiling mounting bracket designed to mount the sensor with an octagonal or square junction box.	
 RMB-500	R	Ceiling Recess The RMB-500 is for recess mounting the sensor through a 2.8" (70mm) hole on the ceiling. An optional back cover (BC-500) is available for separate purchase if cable strain relief is required.	
 IMB-500	I	Fixture Internal The IMB-500 is a mounting bracket exclusively designed for mounting the HFD sensor inside of an OEM lighting fixture.	

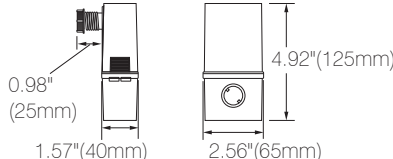
Accessories

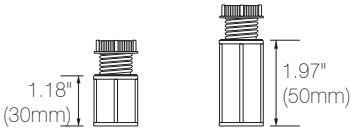
Accessory	Description	Dimensions
 EMA-500	Extension Mounting Adaptor The EMA-500 is an extension mounting adaptor for lowering the position of E-mount sensor to avoid the coverage being blocked by the fixture body.	
 EJ-30 EJ-50 	Extension Joint The EJ-30 and EJ-50 are extension joints that can be used to horizontally extend the E/P mount TRANS sensor position for 30 and 50 mm. If longer extension is required, combine two joints for 60/80/100 mm. For outdoor use, order EJ-30F or EJ-50F .	

TRANS PIR Occupancy Sensor LENS DATASHEET

OVERVIEW

All TRANS PIR based Occupancy Sensors feature with interchangeable lens options. Each lens provides different sensing coverage which varies with the actual mounting height.

The specified detection coverage and mounting height of each lens are based on the test result of human motion walking across the detection zones. The actual coverage may be reduced if the motion is moving toward or away the sensor. High ambient temperature (above 82°F/28°C) could reduce the coverage of PIR sensor. If ambient temperature at the covered area are expected to be high sometimes, consider adding more sensors or reduce the mounting height, if possible.

The followings are all available lens options and their respective detection patterns at printing time. For details of latest lens options available, please visit www.irtec.com.



LENS OPTIONS

Lens		Shape	Recommended Mounting Height		Coverage
A		Standard	Cone	8~15 ft. 2.4~4.5m	2X height
B		Extra wide	Cone	8~10 ft. 2.4~3.0m	6X height
C		High bay	Cone	15~30 ft. 4.5~9.0m	3X height
D		Standard	Round flat	8~20 ft. 2.4~6.0m	2X height
F		Extra wide	Dome	8~20 ft. 2.4~6.0m	4X height
G		Aisle way	Arch	8~40 ft. 2.4~12.0m	3X height
H		High bay	Dome	30~50 ft. 9.0~15.0m	1X height

NOTE:

- Lens G can be rotated to change the direction of coverage. Its 3X height coverage refers only to the total length, the width of coverage will vary with the mounting height (see table of Lens G section). This lens is not IP-66 rated.
- Lens C/G may be mounted up to 40/50 ft. (12/15m) or higher at the area, providing with large moving object such as forklift trucks. Before installing all sensors, please ensure that the sensor can have optimal detection at desired height.

LENS DATASHEET

TRANS

LENS A 2X Standard

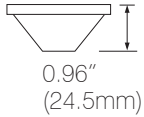

Top View

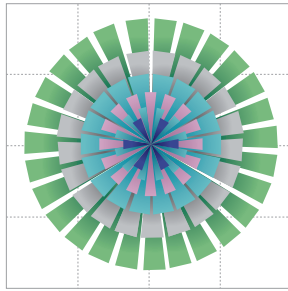

Mounting Height	ft. (m)	8 (2.4)	10 (3.0)	12 (3.6)	15 (4.5)
Max. Coverage Diameter	ft. (m)	16 (4.8)	20 (6.0)	24 (7.2)	30 (9.0)

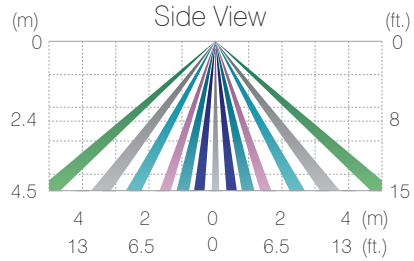

LENS B 6X Extra wide

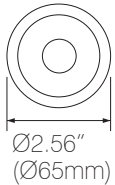
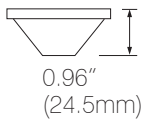

Top View

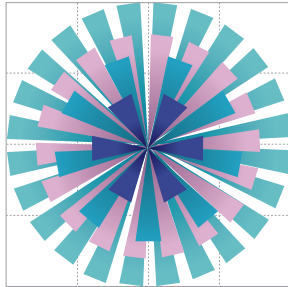

Mounting Height	ft. (m)	8 (2.4)	8.5 (2.6)	9 (2.8)	10 (3.0)
Max. Coverage Diameter	m (ft.)	48 (14.4)	51 (15.6)	54 (16.8)	60 (18.0)

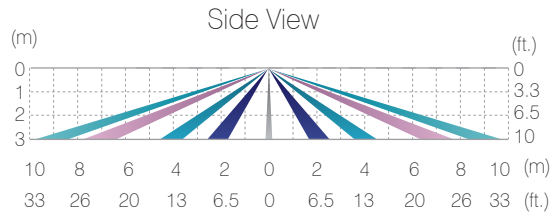

LENS C 3X High bay

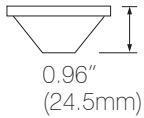

Top View

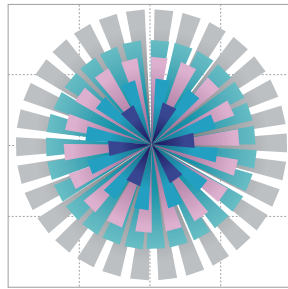

Mounting Height	ft. (m)	15 (4.5)	20 (6.0)	26 (8.0)	30 (9.0)
Max. Coverage Diameter	ft. (m)	45 (13.5)	60 (18.0)	78 (24.0)	90 (27.0)

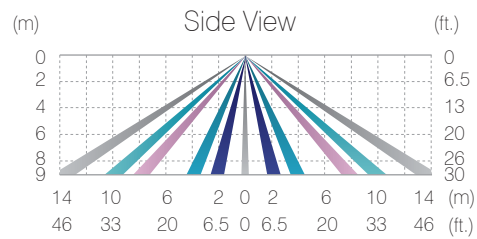

LENS D 2X Standard

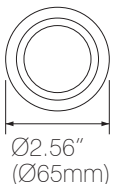
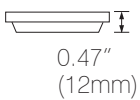

Top View

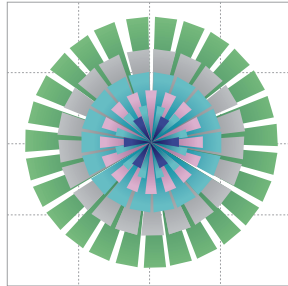

Mounting Height	ft. (m)	8 (2.4)	10 (3.0)	15 (4.5)	20 (6.0)
Max. Coverage Diameter	ft. (m)	16 (4.8)	20 (6.0)	30 (9.0)	40 (12.0)

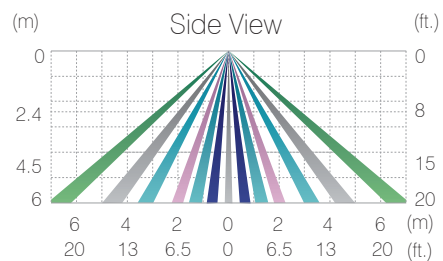

LENS DATASHEET

TRANS

LENS F 4X Extra wide

Mounting Height	ft. (m)	8 (2.4)	10 (3.0)	15 (4.5)	20 (6.0)
Max. Coverage Diameter	ft. (m)	32 (9.6)	40 (12.0)	60 (18.0)	80 (24.0)

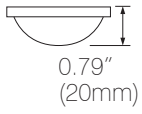

Top View

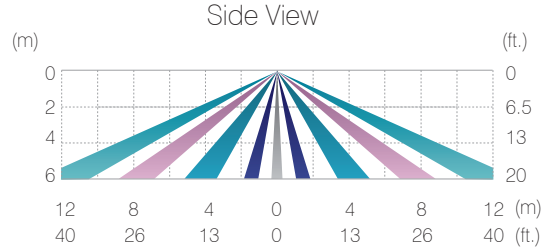
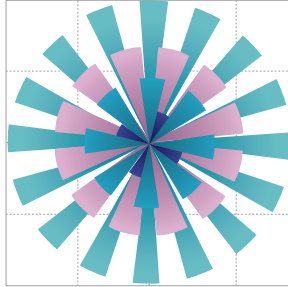

LENS G 3X Aisle way

Mounting Height	ft. (m)	10 (3.0)	20 (6.0)	30 (9.0)	40 (12.0)
Max. Coverage Length x Width	ft. (m)	30 x 3.3 (9.0 x 1)	60 x 6.5 (18.0 x 2)	90 x 10 (27.0 x 3)	120 x 13 (36.0 x 4)

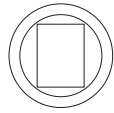
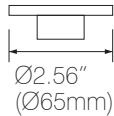
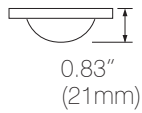

Top View

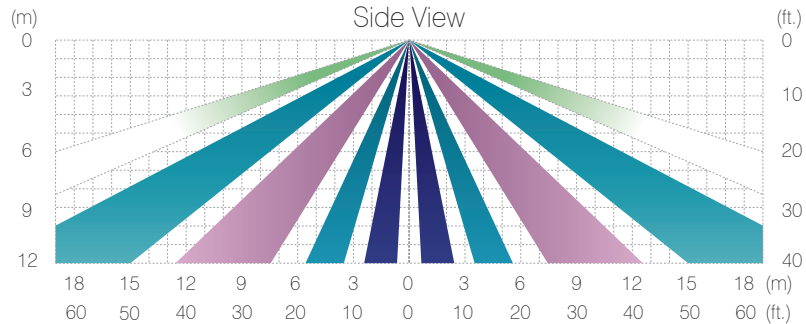
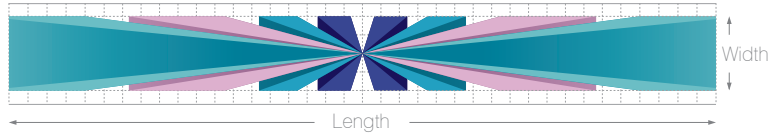

LENS H 1X High bay

Mounting Height	ft. (m)	30 (9.0)	36 (11.0)	43 (13.0)	49 (15.0)
Max. Coverage Length x Width	ft. (m)	20 (9.0)	36 (11.0)	43 (13.0)	49 (15.0)

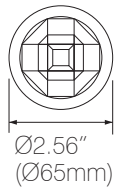
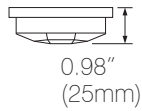

Top View

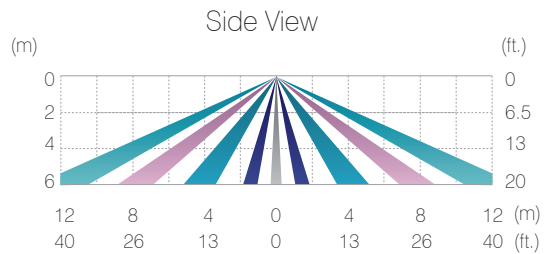
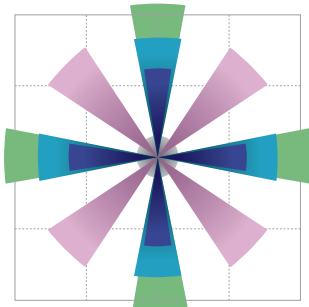

ACCESSORIES

LENS HOOD LH-110

The LH-110 is designed for bi-level control sensors to prevent its ambient light sensor from being saturated by the excessive lighting nearby.

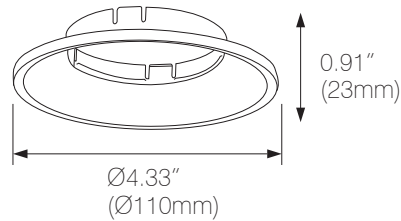

1

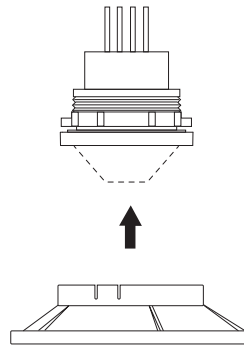

2

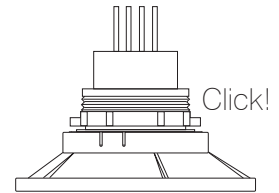

LENS MASK

LM-12C
For Lens A/B/C

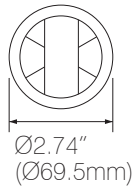
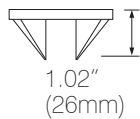

LM-12D
For Lens F

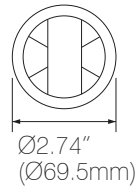
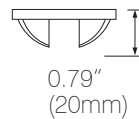

① Push the mask onto the installed lens

1

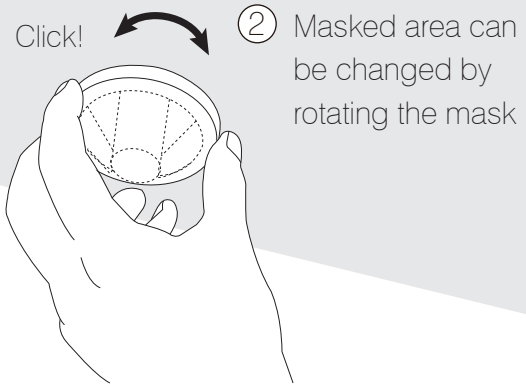

Example: Lens F with LM-12D

Top View

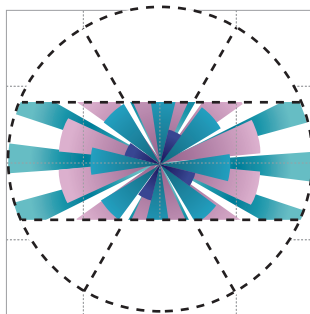

If necessary, the masked area can be altered by cutting off the respective grooved segments with a wire cutter or knife.

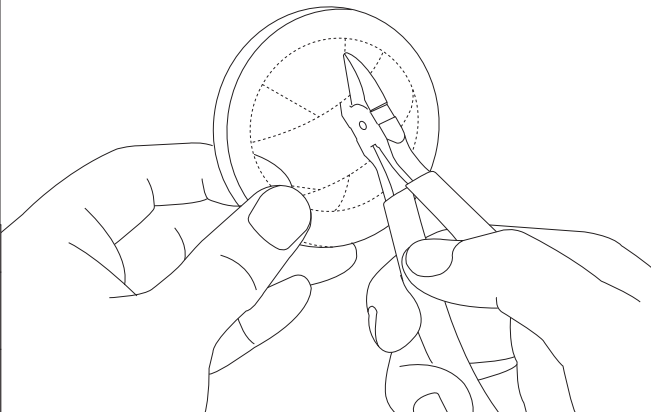

Coverage Area with Lens F and Mask

Mounting Height	ft. (m)	8 (2.4)	10 (3.0)	15 (4.5)	20 (6.0)
Max. Coverage Length x Width	ft. (m)	32 x 3.3 (9.6 x 1)	40 x 6.5 (12.0 x 2)	60 x 10 (18.0 x 3)	80 x 13 (24.0 x 4)