



GTX[®]

City ELA Model LED Signal Modules

8 and 12 inch

Incandescent look (120V)



Project Name _____

Date _____ Type _____

Notes _____



BUILT TO LAST

- Robust thermal management for longer life.
- Optimized opto-electrical system for long lifetimes and extreme field temperature conditions.

INNOVATIVE DESIGN

- Low profile module permits efficient installation into existing traffic housings.
- Power consumption levels allow compatibility with most controllers.
- Mask compatible to fit your unique signaling needs.*

OUTSTANDING PERFORMANCE

- High-brightness central light source and custom optical lensing distribute light uniformly and efficiently.
- Rigorously tested for long life design and low maintenance costs.
- Excellent color uniformity.

MEETS RIGOROUS CERTIFICATION & TESTING STANDARDS

- Intertek ETL Verified compliant.
- Compliant with ITE VTCSH LED Circular Signal Supplement dated June 27th 2005.
- CSA approved version available.

* Sold separately. Refer to masks datasheet TRAF208.



The Greatest Signals Stand the Test of Time.™



GTX® City ELA Model LED Signal Modules

8 and 12 inch

Project Name _____

Date _____ Type _____

Notes _____

Mechanical Outline

Dimensions in inches (mm)

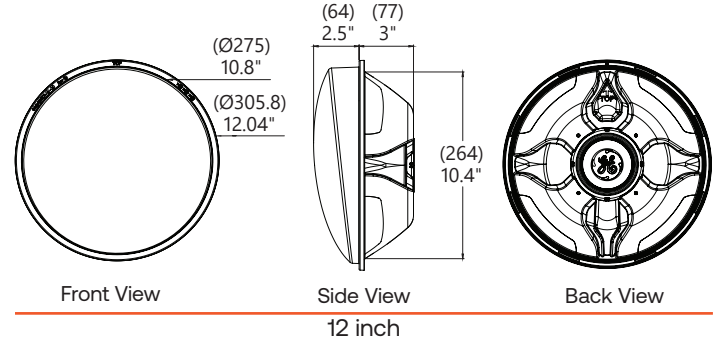
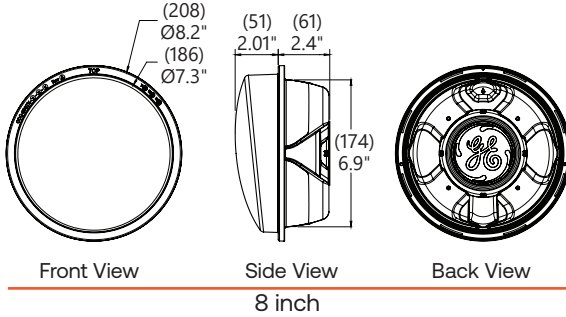

Design Compliance

Test type	Compliance
Luminous Intensity	ITE VTCSH- LED Circular Signal Supplement-June 2005
Chromaticity	ITE VTCSH- LED Circular-June 2005
Moisture Resistance	Blown Wind Rain MIL-STD-810F method 506.4
Mechanical Vibration	MIL-STD-883 Method 2007
Electronic Noise	FCC Title 47 Sub. B Sec 15 ¹
Transient Voltage Protection	Sec. 2.1.6 NEMA TS2-2003, 300V, 2500W Sec. 2.1.6 NEMA TS2-2003, 600V, 10µF Sec. 2.1.8 NEMA TS2-2003, 1kV, 2Ω
Controller Compatibility	ITE VTCSH- LED Circular Signal Supplement-June 2005
Wiring	NFPA 70, National Electric Code
Transient Suppression	Sec. 8.2 IEC 61000-4-5 & Sec. 6.1.2 ANSI/IEEE C62.41.2 - 2002, 3KV, 2 Ω Sec. 8.0 IEC 61000-4-12 & Sec. 6.1.1 ANSI/IEEE C62.41.2 - 2002, 6KV, 30 Ω
Immunity	Radiated electromagnetic field immunity - radio frequencies IEC 6100-4-3:2020 10 V/m (80 MHz-1 GHz) - Class A

Operating Specifications

Parameter	Rating
Operating Temperature Range*	-40 to +74°C (-40 to +165°F)
Operating Voltage Range	80 to 135 V (60Hz AC)
Power Factor (PF)	> 90%
Total Harmonic Distortion (THD)	< 20%
Minimum Voltage Turn-Off (VTO)	35 V
Turn-On/Turn-Off Time	< 75 ms
Lens & Shell Material	UV Stabilized Polycarbonate
Wiring	8 in lamp: 40 in, 20 AWG, Color Coded with Strain Relief ** 12 in lamp: 40 in, 20 AWG, Color Coded with Strain Relief **

* Operating Temperature Range per ITE 2005, Section 3.3.2

** For CSA approved version: 40in, 18AWG, Color Coded with Strain Relief

Product Information

Model Number	Front Shell	Size (in)	AC Voltage Nominal	Power (W) Nominal	Wavelength (nm) Nominal	Maintained Intensity (Cd) Minimum ²
● DR4-RTFB-ELA	Tinted	8	120V - 60Hz	5.3	628	165
○ DR4-RCFB-ELA	Clear					
● DR4-YTFB-ELA	Tinted	8	120V - 60Hz	5.3	589	410
○ DR4-YCFB-ELA	Clear					
● DR4-GTFB-ELA	Tinted	8	120V - 60Hz	5.3	499	215
○ DR4-GCFB-ELA	Clear					
● DR6-RTFB-ELA	Tinted	12	120V - 60Hz	5.3	625	365
○ DR6-RCFB-ELA	Clear					
● DR6-YTFB-ELA	Tinted	12	120V - 60Hz	7.8	589	910
○ DR6-YCFB-ELA	Clear					
● DR6-GTFB-ELA	Tinted	12	120V - 60Hz	6.3	501	475
○ DR6-GCFB-ELA	Clear					

Distributed by:

Standard product equipped with universal connectors (insulated spade-quick disconnect).
All colors available in tinted or clear lens.

¹ Class A

² Measured at vertical angle of -2.5° and at horizontal angle of 0°.