



Allanson

EESB Electronic Fluorescent Sign Ballasts

*Up to 40% More Efficient
than Magnetic Ballasts*



Product Details

- Available in 120 volt and multi-voltage (208V to 347V)
- Instant start-easy to use red/blue wiring
- For use with T12 HO, T8 HO and Slimline Lamps
- Minimum starting temp -30°C
- Light weight from 2 to 9.5 lbs
- Run cooler than conventional magnetic ballasts
- 4 year warranty
- Title 24 Compliant



ENERGY SAVINGS

LOOK FOR THIS MARK SIGNIFYING
ENERGY SAVING PRODUCTS
FROM ALLANSON.

FLUORESCENT-06-12



Fluorescent



Allanson

EESB Electronic Fluorescent Sign Ballasts

Specifications

Model	Lamp-Foot (T12)	Lamp-Foot (T8)	Lamps	Amps at 120V (T12)	Amps at 120V (T8)	Watts	OCV	Weight	Competitive
EESB-1808-1L	18" -8'	18"-8'	1	0.85	1.00	107	800	2	
EESB-0216-12L 120-277V	2'-16'	2'-12'	1,2	1.20	1.10	124	980	2.5	ESB-216-12
EESB-424-13L	4'-24'	4'-24'	1,2,3	1.50	1.80	176	750	5	
EESB-0432-14L 120-277V	4'-32'	4'-24'	1,2,3,4	2.35	2.25	247	980	9.5	ESB-432-14
EESB-832-16L	8'-32'	8'-32'	1,2,3,4,5,6	2.40	3.00	268	800	8	
EESB-1040-14L	10'-40'	10'-40'	1,2,3,4	2.75	N/A	332	850	8	ESB-1040-14
EESB-1048-26L	10'-48'	10'-48'	2,3,4,5,6	3.00	3.50	344	800	8	ESB-848-46

Specifications

Model	Lamp-Foot (T12)	Lamp-Foot (T8)	Lamps	Amps at 208V	Amps at 347V	OCV	Weight
EESB-424-13MV	4'-24'	4'-24'	1,2,3	1.20	0.70	700	5
EESB-832-16MV	8'-32'	8'-32'	1,2,3,4,5,6	1.50	1.00	800	8
EESB-1040-14MV	10'-40'	10'-40'	1,2,3,4	1.80	1.00	900	8
EESB-1048-26MV	10'-48'	10'-48'	2,3,4,5,6	2.20	1.50	800	8

MV= 208V to 347V

Visit us at www.allanson.com

US
 Phone 1.800.559.3659
 Fax 1.615.643.1890
 Email customerservice@eballast.com

CANADA
 1.800.661.7251
 1.416.752.6717
custserv@allanson.com



Fluorescent

EESB Ballast - Wiring Diagrams

EESB-1808-1L

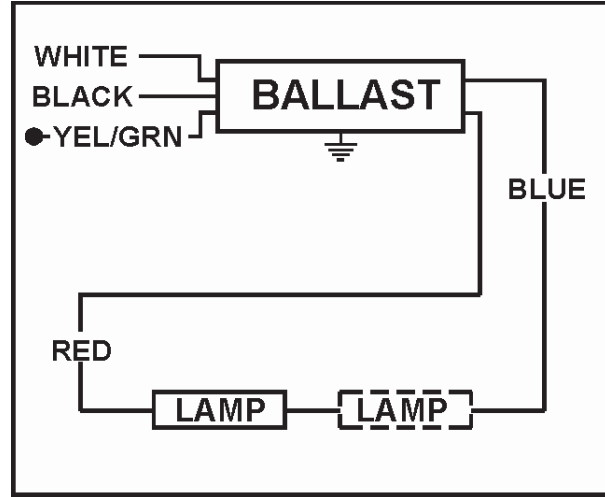
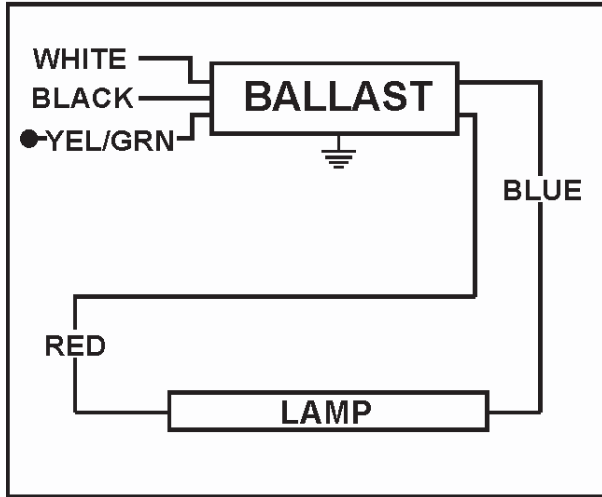

EESB-416-2L & EESB0216-12L-120-277V

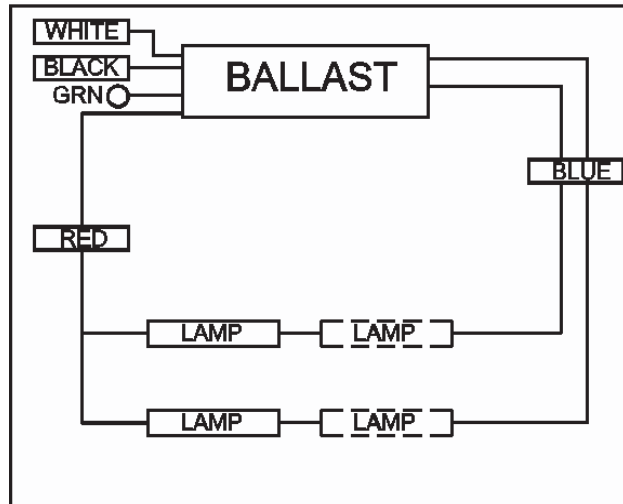
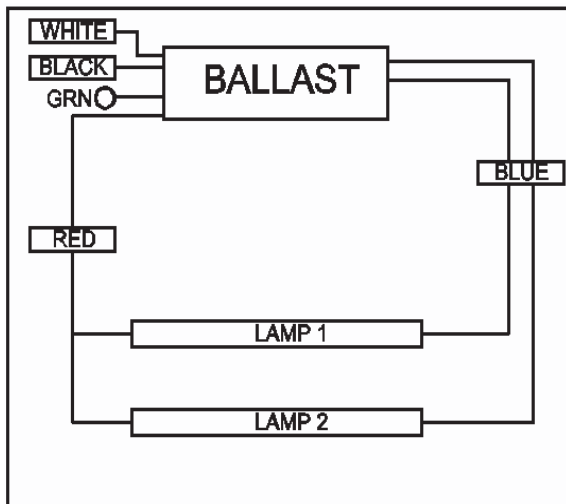

EESB-424-13L & EESB-424-13MV

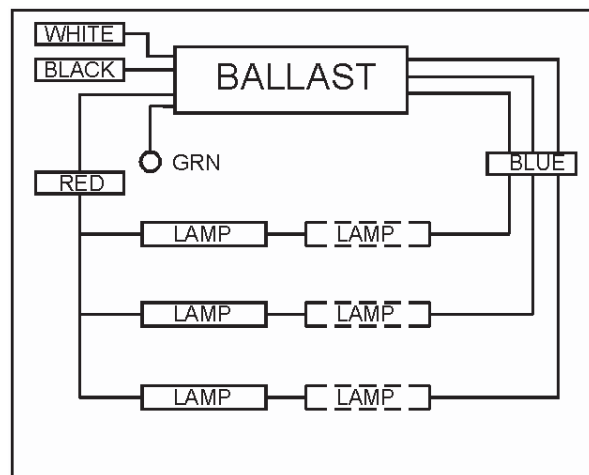
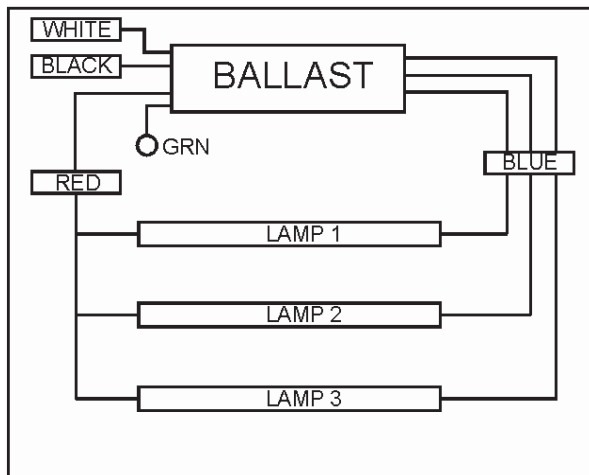

EESB Ballast - Wiring Diagrams

EESB-1040-14L, EESB-1040-14MV & EESB-0432-14L-120-277V

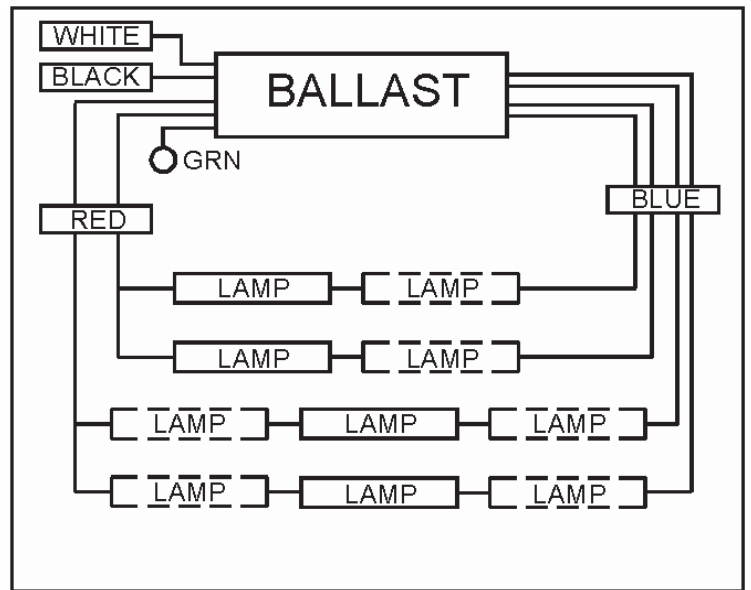
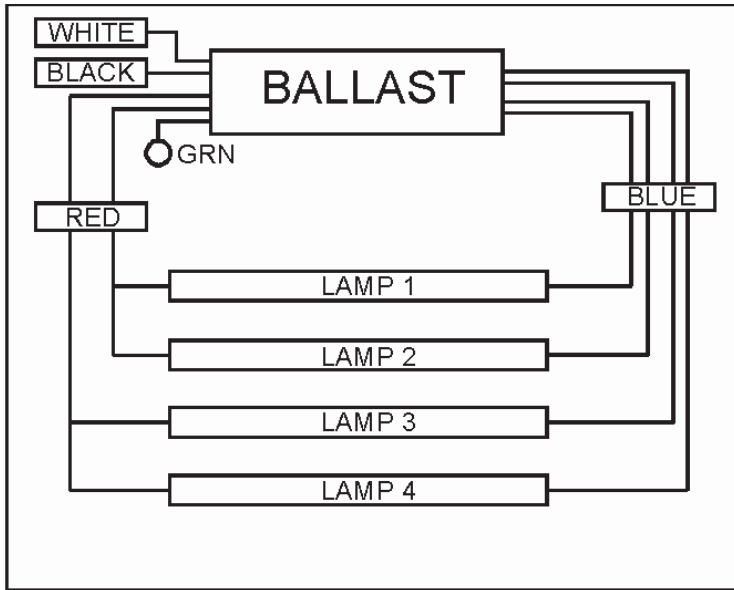

EESB-832-16L / MV, EESB-1048-26L / MV

EESB-1048-26L-120-277V & EESB-0250-26L-120-277V

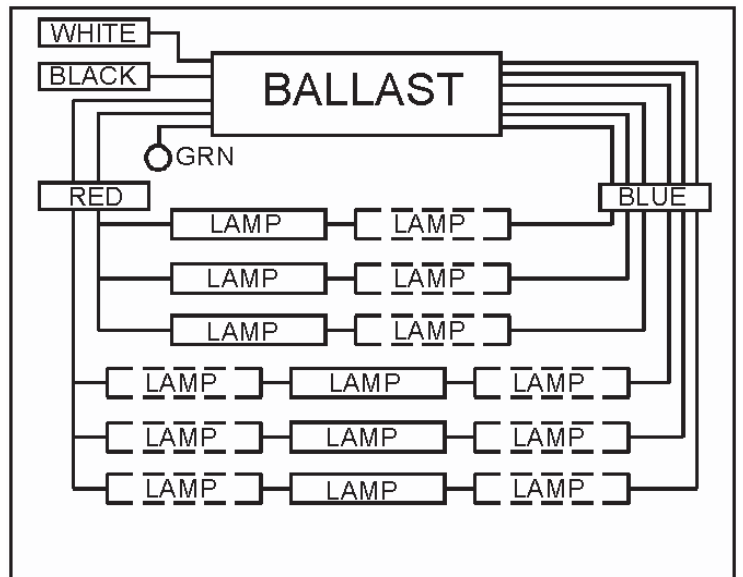
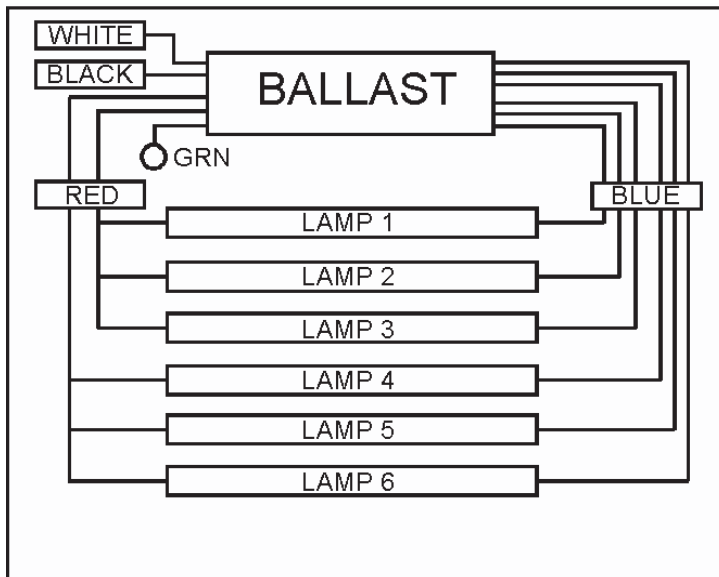

Allanson **LIGHTING COMPONENTS**

Tomorrow's Products Today™



ELECTRONIC SIGN ILLUMINATING PRODUCTS

Electronic Outdoor
Sign Ballasts



HO SOCKETS



A NEW STANDARD OF EXCELLENCE



Tomorrow's Products Today™

Welcome to the New Allanson/Lighting Components Electronic Sign Illuminating Products Catalog. At Allanson/Lighting Components we are committed to being your partner in sign fabrication and repair. This full line of electronic ballasts features the latest technology for illuminating fluorescent signs. This means significant energy savings to protect the planet and save money. Plus, we offer a full line of Magnetic Luminous Tube Neon Transformers, HID Sign Ballasts, Plastic Sign Fluorescent Ballasts, and Accessories. Allanson/Lighting Components can offer precisely the right product to fit your needs. Designed and built to meet Allanson/Lighting Components' demanding specifications, all of our products are guaranteed to perform. Please contact us for your next sign project to see how Allanson/Lighting Components can perform for you.

48 Month Warranty on Electronic Sign Ballasts

ALLANSON/LIGHTING COMPONENTS INC. warrants to the original purchaser the products described herein to be free from defects in material and workmanship at the date of shipment. NO OTHER WARRANTY, WHETHER EXPRESS OR IMPLIED, INCLUDING ANY WARRANTY OF MERCHANTABILITY OR FITNESS FOR A PARTICULAR PURPOSE, SHALL EXIST IN CONNECTION WITH SALE OR USE OF SUCH PRODUCTS. All claims under this warranty must be made in writing and delivered to the Company prior to the expiration of four years from the date of manufacture. Upon receipt of claim, the Company shall inspect the part or parts which the Company determines to have been defective, and the Company shall repair, or at its option, replace, free of charge, any part or parts which the Company determines to have been defective at the time of the shipment from the factory; provided, however, that if circumstances are such as to preclude the remedying of warranted defects by repair or replacement, the Company shall, upon return of the products, refund to the buyer any part of the purchase price of the products theretofore paid to the Company. Inspection shall, at Company's option, be performed at the Company's plant, or at such other place as may be designated by the Company, and in such event freight for returning products to Company's plant or to such other designated place shall be paid by buyer.

The foregoing states the sole and exclusive remedy for any breach of warranty or for any other claim based on any defect in, or non-performance of, the products, whether sounding in contract, warranty, or negligence. WITHOUT LIMITING THE GENERALITY OF THE FOREGOING, THE COMPANY SHALL UNDER NO CIRCUMSTANCES BE LIABLE FOR ANY INCIDENTAL OR CONSEQUENTIAL LOSS OR DAMAGE WHATSOEVER ARISING OUT OF, OR IN ANY WAY RELATING TO, ANY SUCH BREACH OF WARRANTY OR CLAIMED DEFECT IN, OR NON-PERFORMANCE OF, THE PRODUCTS.

ALLANSON/LIGHTING COMPONENTS' ELECTRONIC ENERGY EFFICIENT SIGN BALLASTS KEEP YOUR SIGN COOL.

Infrared photography tells the story!

The infrared photos below show the excessive heat generated in a magnetic ballast and the filaments of the lamps it powers.

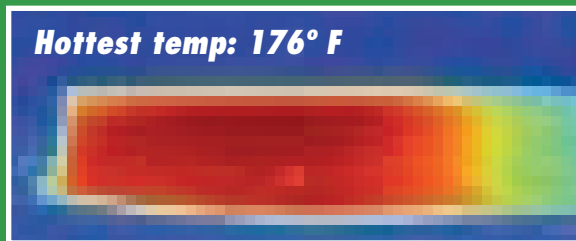
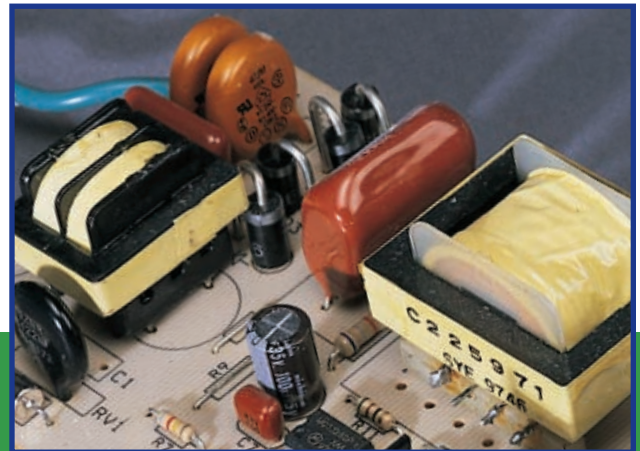

Conventional Magnetic Ballast

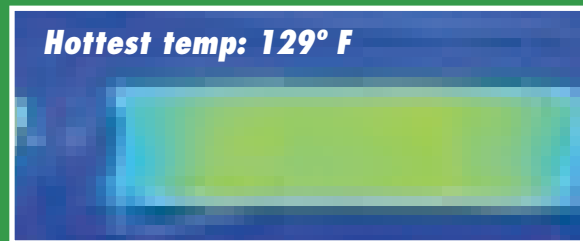

EESB-1048-26L Electronic Ballast

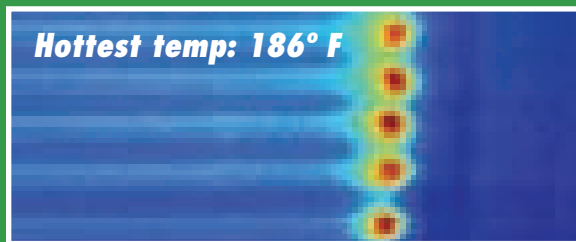

Lamps Powered by Magnetic Ballast



Lamps Powered By EESB-1048-26L

EESB Series Ballasts last years longer!

This results in significant savings in maintenance and replacement costs.

Protect the Environment while Saving Money!

The positive effects of reduced energy consumption are well documented. Save precious natural resources, lessen the need for power plants, reduce acid rain and more.

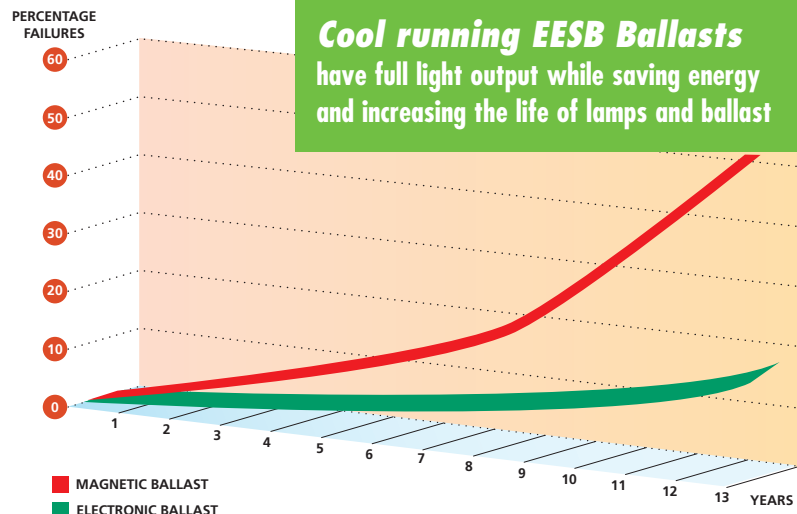

EESB SERIES ELECTRONIC SIGN BALLASTS

Multi-Lamping options make inventory management Easy!

For use with T12 HO, T8 HO, and Slimline Lamps 120 Volts, 50/60Hz (Min. starting temperature -20°F)

Using 800mA T12/HO Lamps Standard

Lamp Data		Footage		Catalog Number	Max Line		Max	Open	Wiring Diagram	Weight lbs.
No. of Lamps	Min.	Max.	Current Amps Label		Actual	Input Watts	Current Voltage			
1	18"	8	EESB-1808-1L	.85	.80	107	800	1, 7	2	
1,2	4	16	EESB-416-12L	1.55	1.51	180	850	2, 8	3	
1,3	4	24	EESB-424-13L	1.50	1.47	176	750	3, 9	5	
1,6	8	32	EESB-832-16L	2.40	2.21	268	800	4, 10	8	
* 1,4	10	40	EESB-1040-14L	2.75	2.70	332	850	5, 11	8	
2,6	10	48	EESB-1048-26L	3.00	2.88	344	800	6, 12	8	

* For use with 4- 10' Lamps

EESB Multi-Voltage Ballasts provide even greater flexibility!



For use with T12 HO, T8 HO, and Slimline Lamps 120/220/240/277 Volts, 50/60Hz (Min. starting temperature -20°F)

Using 800mA T12/HO Lamps Standard

Lamp Data		Footage		Catalog Number	Max Line		Max	Open	Wiring Diagram	Weight lbs.
No. of Lamps	Min.	Max.	Current Amps Label		Actual	Input Watts	Current Voltage			
+ 2,6	10	48	EESB-1048-26L 120-277V	120V	3.10	2.86	347	980	6-12	9
				208V		1.63	340			
				240V		1.41	338			
				277V	1.50	1.24	339			
* 1,6	2	50	EESB-0250-16L 120-277V	120V	3.54	3.30	395	980	6-12	8
				208V		1.83	384			
				240V		1.59	382			
				277V	1.65	1.39	381			
1,4	4	32	EESB-0432-14L 120-277V	120V	2.35	2.25	271	980	5-11	9.5
				208V		1.30	270			
				240V		1.18	271			
				277V	1.10	1.02	272			
1,2	2	16	EESB-0216-12L 120-277V	120V	1.20	1.11	134	980	2-8	2.5
				208V		0.64	133			
				240V		0.58	135			
				277V	0.55	0.51	136			

+ For use with 4- 10' T12 HO Lamps

* The Ultimate Sign Ballast for use with 800mA T12 HO, T8 HO, T8 Long Life, and Slimline Lamps

EESB SERIES ELECTRONIC SIGN BALLASTS

EESB Multi-Voltage Ballasts provide even greater flexibility!

Using 375 mA, T8 HO Lamps

Lamp Data		Footage		Catalog Number		Max Line		Max	Open	Wiring Diagram	Weight lbs.
No. of Lamps	Min.	Max.				Current	Amps	Input Watts	Current Voltage		
						Label	Actual				
2,6	10	48	EESB-1048-26L	120-277V	120V	3.65	3.57	427	980	6-12	9
					208V		2.06	427			
					240V		1.82	428			
					277V	1.75	1.60	428			
1,6	2	48	EESB-0250-16L	120-277V	120V	3.65	3.57	427	980	6-12	8
					208V		2.06	427			
					240V		1.82	428			
					277V	1.75	1.60	428			
1,4	4	24	EESB-0432-14L	120-277V	120V	2.25	2.06	247	980	5-11	9.5
					208V		1.19	248			
					240V		1.04	248			
					277V	1.05	0.91	249			
1,2	2	12	EESB-0216-12L	120-277V	120V	1.10	1.05	124	980	2-8	2.5
					208V		0.61	124			
					240V		0.53	125			
					277V	0.50	0.47	125			

Using 315 mA, T8 Long Life Lamp

Lamp Data		Footage		Catalog Number		Max Line		Max	Open	Wiring Diagram	Weight lbs.
No. of Lamps	Min.	Max.				Current	Amps	Input Watts	Current Voltage		
						Label	Actual				
1,6	2	48	EESB-0250-16L	120-277V	120V	3.55	3.48	418	980	6-12	8
					208V		2.01	416			
					240V		1.71	416			
					277V	1.65	1.51	416			

For use with T12 HO, T8 HO, and Slimline Lamps 208/220/240/277/347 Volts, 50/60Hz (Min. starting temperature -20°F)

Using T12/HO Lamps Standard

Lamp Data		Footage		Catalog Number		Max Line		Max	Open	Wiring Diagram	Weight lbs.
No. of Lamps	Min.	Max.				Current	Amps	Input Watts	Circuit Voltage		
						Label	Actual				
1,3	4	24	EESB-424-13MV	208V	240V	1.20	.809	167	700	3, 9	5
							.708	169			
							.622	171			
							.508	172			
2,6	10	48	EESB-1048-26MV	208V	240V	2.2	1.57	327	800	6, 12	8
							1.37	327			
							1.19	328			
							.955	329			

EESB SERIES ELECTRONIC SIGN BALLASTS WIRING DIAGRAMS / LEAD LENGTHS AND CASE DIMENSIONS

Lead Lengths and Case Dimensions

Catalog Number	Lead Length (Feet)				Dimensions (inches)			
	Black	White	Red	Blue	Length	Width	Height	Mounting
EESB-1808-1L	2	2	11	11	9-1/2	2-3/8	1-5/8	8-7/8
EESB-416-12L	2	2	11	11	11-3/4	2-3/16	1-5/8	11
EESB-424-13L/MV	2	2	11	11	11-3/4	3	1-3/4	11-1/8
EESB-832-16L/MV	2	2	11	11	14-7/16	3	2-3/4	13-3/4
EESB-1040-14L/MV	2	2	11	11	14-7/16	3	2-3/4	13-3/4
EESB-1048-26L/MV	2	2	11	11	14-7/16	3	2-3/4	13-3/4
EESB-0216-12L-120-277V	2	2	11	11	9-1/2	2-3/8	1-5/8	8-7/8
EESB-0432-14L-120-277V	2	2	11	11	14-7/16	3	2-3/4	13-3/4
EESB-1048-26L-120-277V	2	2	11	11	14-7/16	3	2-3/4	13-3/4
EESB-0250-16L-120-277V	2	2	11	11	14-7/16	3	2-3/4	13-3/4

WIRING DIAGRAM 1



WIRING DIAGRAM 2

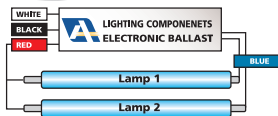

WIRING DIAGRAM 3

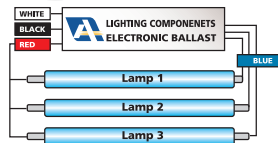

WIRING DIAGRAM 7

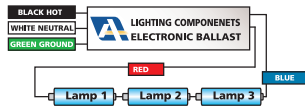

WIRING DIAGRAM 8

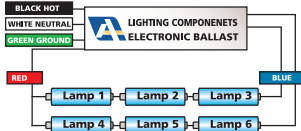

WIRING DIAGRAM 9

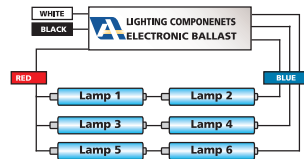

WIRING DIAGRAM 4

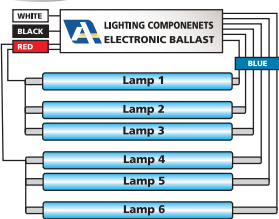

WIRING DIAGRAM 5

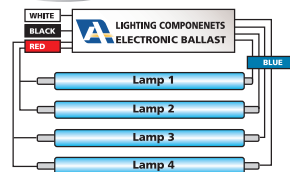

WIRING DIAGRAM 6

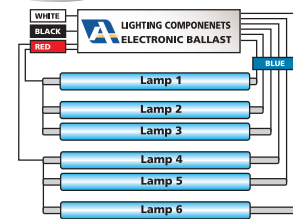

WIRING DIAGRAM 10

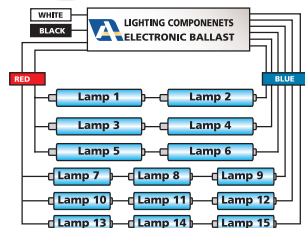

WIRING DIAGRAM 11

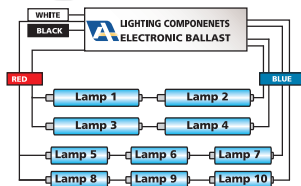

WIRING DIAGRAM 12

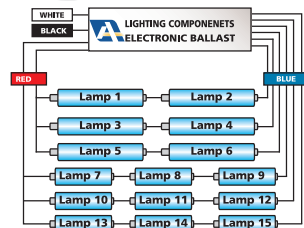

NEW ELECTRONIC SIGN BALLASTS PAY FOR THEMSELVES IN ONE YEAR!

For the past 25 years, electronic ballasts have been bringing dramatic cost savings to the fluorescent lighting fixture industry. Now that same advanced technology is available for your outdoor and indoor sign applications! Our new patented electronic H.O. sign ballasts replace all those heavy, hot operating, power hungry magnetic ballasts with light, cool operating, energy efficient electronic H.O. Ballasts. While saving energy, you'll extend lamp life by 30% and reduce installation labor cost by 50%. Each EESB ballast is an investment which earns you money every day it operates!

You can do the math for your own application; it's easy. Get your last electric bill and multiply the cost per watt by the watts saved using EESB ballasts. Each magnetic ballast you replace with Allanson/Lighting Components' EESB-1048 ballast can **save in one year** more than enough to pay for the ballast and replacement labor.

	WATTS USED		ENERGY COSTS PER WATT BY STATE*			
	Watts used per hour	12 hrs/day 365 days/yr	New York 0.00012	California 0.00010	Illinois 0.00008	Texas 0.00007
1 – Standard 6-8' lamp ballast, 120 volt	610	2,671,800	\$ 321	\$ 267	\$ 214	\$ 187
1 – EESB energy saving ballast, 120 volt	344	1,506,720	\$ 180	\$ 150	\$ 120	\$ 105
Yearly Savings						
Savings with just 1 EESB ballast!		1,165,080 WATTS SAVED	\$ 140	\$ 117	\$ 92	\$ 82
Savings with just 20 EESB ballasts!		23,391,600 WATTS SAVED	\$ 2,800 <i>20 ballasts</i>	\$ 2,340	\$ 1,840	\$ 1,640
Savings—20 EESB ballasts in 100 locations!		This is 2.3 BILLION 2,330,160,000 WATTS SAVED	\$280,000 <i>2,000 ballasts</i> SAVE EACH YEAR	\$234,000 SAVE EACH YEAR	\$184,000 SAVE EACH YEAR	\$164,000 SAVE EACH YEAR

*(2000 NY Policy Institute)

Enhance your company's energy saving image & improve the bottom line. Get the Allanson / Lighting Components EESB ballast: it's a win-win decision!

- 40% more efficient than magnetic ballast! See the cost savings example above
- Operate combinations of one to six T12 H.O., T8 H.O., T8 Long Life, and Slimline lamps from 18 in. to 50 ft. in total length
- Starts lamps at -20° F
- Lowest operating temperature in the industry—Adds life to lamp and ballast
- Best voltage regulation available anywhere—70v to 305v line voltage
- Lightweight—2 to 9.5 lbs.
- First month's energy savings will more than offset the additional cost, if any, of the EESB Ballast
- 4 year warranty
- U. L. listed and C.S.A. approved to operate T12 H.O., T8 H.O., T8 Long Life, and Slimline lamps.
- Title 24 Compliant

EESB ELECTRONIC BALLASTS VS. MAGNETIC BALLASTS

- U. L. listed and C.S.A. approved to operate the following lamps: T12 H.O., T8 H.O., T8 Long Life, and Slimline lamps.
- Power consumption is 40% less than a comparable magnetic ballast. The best in the sign industry!
- Lowest starting temperature (-20°F) and the lowest case operating temperature.
- Total harmonic distortion is less than 10%, with low in-rush current for optimal system performance.
- The best voltage regulation in the industry... operates at line voltages of 70V - 135V, MV Ballast 108 - 305.

Ballast 120V	Max. # 8 Ft. Lamps	# Units on 15A Circuit	Input Wattage	Lead Length	Warranty Months	Weight lbs.	Energy Efficiency	% THD
EESB-424-13L	3	8	176	11'	48	5	92%	5%
Magnetic	3	4	325	6'	24	14	49%	24%
EESB-832-16L	4	5	268	11'	48	8	92%	8%
Magnetic	4	3	375	6'	24	19	49%	26%
EESB-1040-14L	4-10' Lamps	4	332	11'	48	8	92%	8%
Magnetic	4	2	520	6'	24	18	48%	28%
EESB-1048-26L	6	4	344	11'	48	8	92%	8%
Magnetic	6	2	610	6'	24	24	45%	24%

Designed for flexibility of application. You need to stock **just six ballasts** to operate one to six 800mA High Output Rapid Start and Slimline Lamps from 18" to 50' in total length. Electronic ballast design and construction is so reliable, we offer a **48 month warranty... twice as long as most magnetic ballast manufacturers.**

- Ballast catalog number readily identifies lamp footage and number of lamps for each ballast
- Ballast fill material has superior thermal conductivity to efficiently dissipate heat from the ballast for longer life.
- White, highly luminous corrosion-resistant finish provides added weather resistance.
- Ballast leads exit at bottom for ease-of-use within raceways.



Patented and patents pending.
U. L. Listed and C.S.A. Approved



Packed individually for your convenience!

Each EESB Ballast is packed in an individual carton for ease of handling and to prevent the leads from becoming tangled with other ballasts. The catalog number, lamp footage range and number of lamps the ballast can operate are all clearly indicated on the end panel of the carton. Cartons are also clearly date-coded to help you keep stock current.



Use Lead Covers for added moisture protection and splice box capability.



1 - 8 0 0 / 5 5 9 - 3 6 5 9

FLUORESCENT COMPONENTS

H.O. and V.H.O. Lamp Holders Tombstone and Flush Mount and Accessories

H.O. Lampholders

Our lampholders are made of a proprietary material and design that earned a listing by Underwriters Laboratories that complies with U. L. 48, U. L. 879, and the Canadian Standards Association C22.2 No. 43-M1984 and C.S.A. C22.2 No. 74.

Features:

- 12" lead length
- Special thermoplastic flexible sealing material designed to expand and contract with temperature changes. Flexibility prevents moisture from coming in contact with the electrical connection as a result of age or temperature changes. It is a self-extinguishing sealer adhesive. It will not crack or deteriorate and lose its strength like clay-based sealers.
- The electrical contacts in our lampholders are made of a material that allows them to remain rigid in the expanded position and make good electrical contact with the lamp after hundreds of relampings.

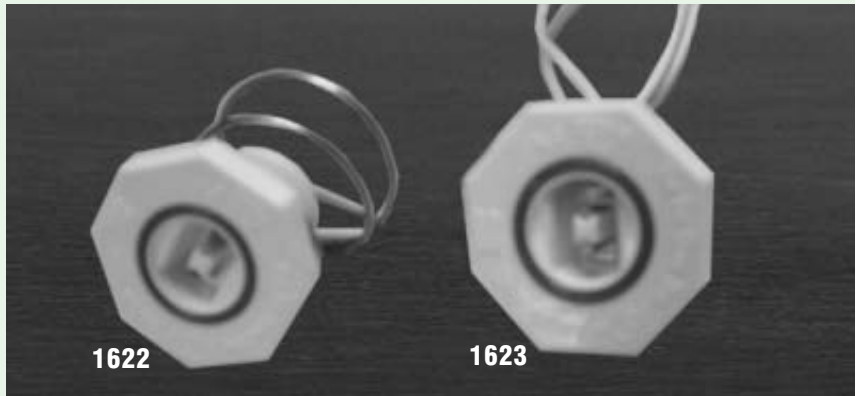

Rated for 660 Watts, dual rated 600 volts or 1000 volts.
U. L. listed and C.S.A. approved for outdoor use in enclosed signs and fixtures.

TP7

Wiring Harness Cover



Distributed by:



US

2273 Hwy 41 South • Greenbrier, TN

Sales and Distribution Center Phone: 1-800/559-3659 • Fax: 1-615/643-1890

email: customerservice@eballast.com

Canada

Phone: 1-800/661-7251 • Fax: 1-416/752-6717

email: custserv@allanson.com