

# Tetra<sup>®</sup> LED Control Module

(GECLPSPH-2)

## LED Control Module Features

- LED Control Module for GECLPSPH.
- UL: Class 2 input.



## BEFORE YOU BEGIN

Read these instructions completely and carefully.

### ⚠ WARNING/AVERTISSEMENT

#### RISK OF ELECTRIC SHOCK

- Disconnect power at fuse box or circuit breaker before servicing or installing product.
- Properly ground Tetra<sup>®</sup> power supply.

#### RISK OF FIRE

- Use only Tetra<sup>®</sup> supply wire to make connection from Tetra<sup>®</sup> power supply to Tetra<sup>®</sup> LED strip.
- Use only approved wire for input/output connection. Minimum size 18 AWG (0.82 mm<sup>2</sup>)
- Follow all local codes.

#### RISQUES DE DÉCHARGES ÉLECTRIQUES

- Coupez l'alimentation électrique à la boîte de fusibles ou au disjoncteur avant l'entretien ou l'installation du produit.
- Assurez-vous de correctement mettre à terre l'alimentation électrique Tetra<sup>®</sup>.

#### RISQUES D'INCENDIE

- N'utilisez que le fil d'approvisionnement Tetra<sup>®</sup> pour faire la connexion entre l'alimentation Tetra<sup>®</sup> et la bande DEL Tetra<sup>®</sup>.
- N'utilisez que des fils approuvés pour les entrées/sorties de connexion. Taille minimum 18 AWG (0.82 mm<sup>2</sup>).
- Respectez tous les codes locaux.

### ⚠ CAUTION/ATTENTION

#### RISK OF INJURY

- While performing installations described, gloves, safety glasses or goggles should be worn.

#### RISQUE DE BLESSURE

- Lors de l'exécution des installations décrites, des gants, des lunettes de sécurité ou des lunettes de protection doivent être portées.

## Save These Instructions

Use only in the manner intended by the manufacturer. If you have any questions, contact the manufacturer.

This device complies with part 15 of the FCC Rules. Operation is subject to the following two conditions: (1) This device may not cause harmful interference, and (2) this device must accept any interference received, including interference that may cause undesired operation.

## Prepare Electrical Wiring



### Electrical Requirements

- Limited to use in dry and damp locations.
- The grounding and bonding of the LED Driver shall be done in accordance with National Electric Code (NEC) Article 600.
- Follow all National Electric Codes (NEC) and local codes.
- These products are only suitable for connection to a circuit from a Class 2 power source. These products have not been evaluated for use when connected to a power source that does not comply with Class 2 voltage and energy limited supplies.

**Note:** This equipment has been tested and found to comply with the limits for a Class A digital device, pursuant to part 15 of the FCC Rules. These limits are designed to provide reasonable protection against harmful interference when the equipment is operated in a commercial environment. This equipment generates, uses, and can radiate radio frequency energy and, if not installed and used in accordance with the instruction manual, may cause harmful interference to radio communications. Operation of this equipment in a residential area is likely to cause harmful interference in which case the user will be required to correct the interference at his own expense.

This Class [A] RFLD complies with the Canadian standard ICES-003. Ce DEFR de la classe [A] est conforme à la NMB-003 du Canada.



imagination at work

## Components

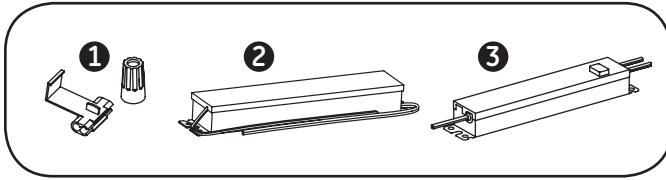

- ❶ UL certified 22-14 AWG (0.33-2.08 mm<sup>2</sup>) wire connectors or 22-18 AWG (0.33-0.82 mm<sup>2</sup>) inline/IDC connectors.
- ❷ Tetra® 24 Volt Power Supply.
- ❸ Tetra® LED Control Module.

## Remove Existing Lighting Equipment

Prior to installation, survey the site for information regarding power and accessibility inside and outside the building. Ensure that the branch circuit supplying the existing LED power supply will be within the voltage ratings of the new LED power supply, and have a current rating not exceeding 20A, or that permitted by applicable local, state, or country electrical codes (whichever is less).

If removal of the existing lighting equipment (see Step 2 in this section) eliminates the disconnect switch, as required by applicable local, state, or country electrical codes; a new disconnect switch must be installed. If required, the disconnect switch shall be installed by qualified personnel, in accordance with applicable local, state, and country electrical codes.

Make sure the removal of lighting equipment does not compromise the integrity of the sign body (i.e. water intrusion). Fill in all holes 0.5 in. (13 mm) or smaller with the appropriate amount of rated caulk or sealant. For holes greater than 0.5 in. (13 mm), use an aluminum or zinc coated steel patch with rivets and sealant.

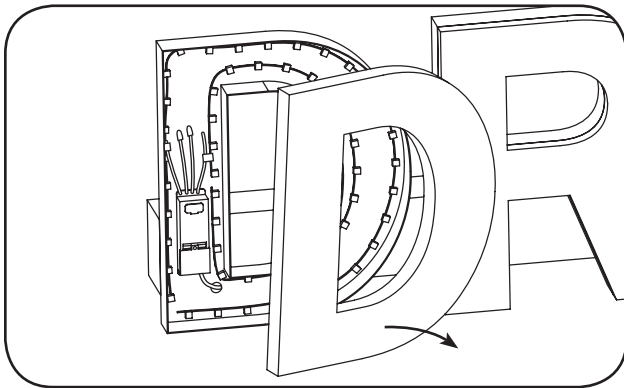

- ❶ Turn off power and remove panel from the channel letter.

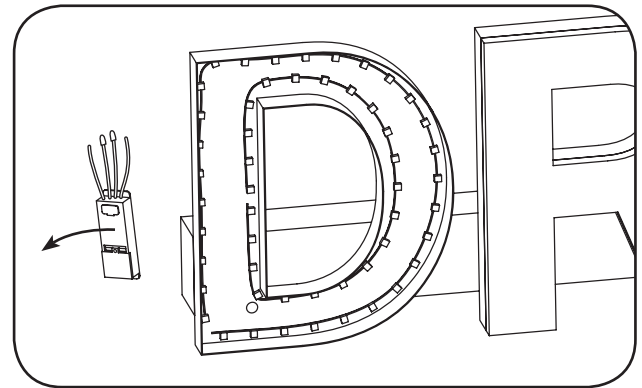

- ❷ Remove the existing GECLPSPH. Do not remove existing channel letters and wiring.

**NOTE:** Follow all federal and local regulations when disposing of existing LED drivers.

## Electrical Connections

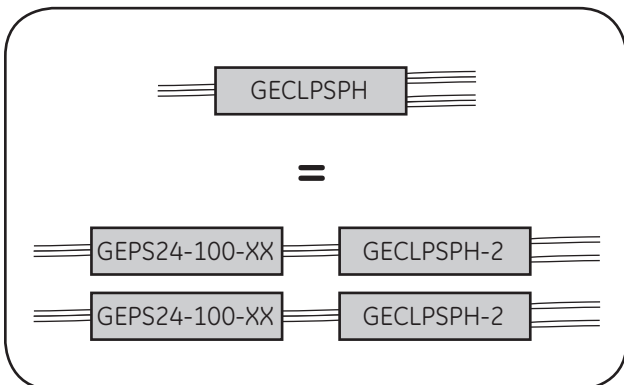

- ❸ Two GECLPSPH-2 and two 24VDC, 100W, Class 2 Tetra LED Drivers will be required to replace each GECLPSPH LED drivers.

**NOTE:** Mount the LED driver and LED control module within the sign or other enclosure.

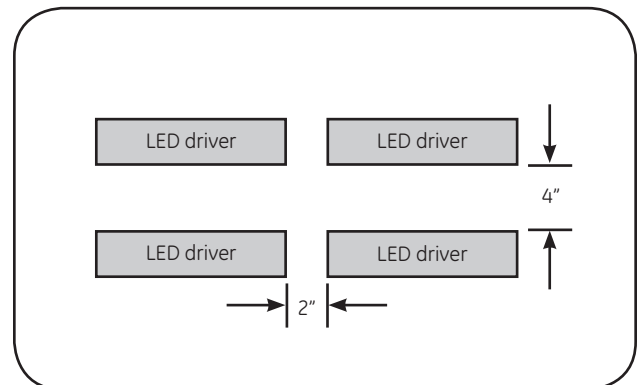

- ❹ If installing multiple LED control modules or LED drivers in the same compartment, keep them at least 2" (50.8mm) apart end to end and 4" (101.6mm) apart along the sides.

**NOTE:** All drivers except GEPS24-180U must be installed in a raceway or be provided with a GEPSJB60 LED driver extended enclosure.

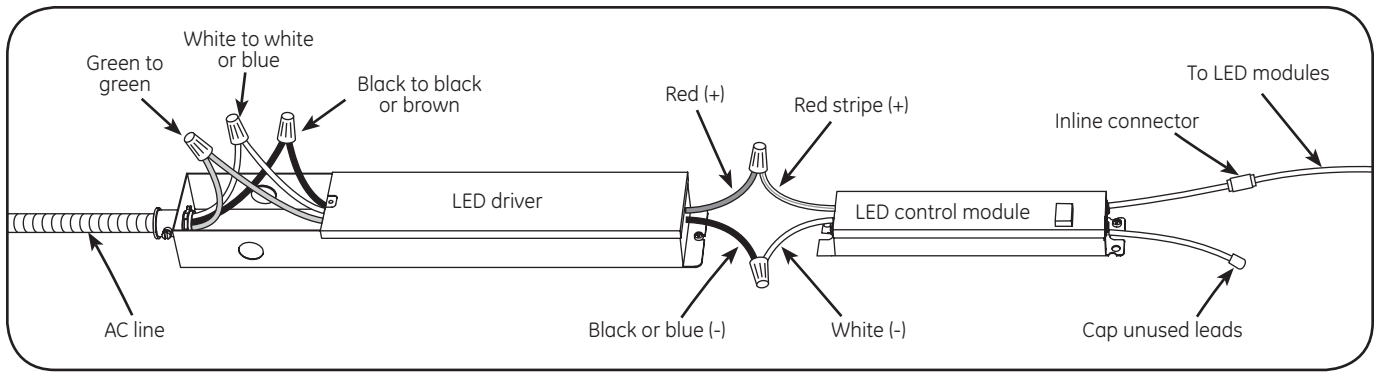

- 5 Wire AC line to LED driver(s) in accordance with the applicable local, state, and country electrical codes. Connect black to black or brown, white to white or blue, and green to green using 18 AWG (0.82mm<sup>2</sup>) wire connectors.
- 6 Connect the red stripe wire (+) of the LED control module to the red wire (+) of the power supply. Connect the white wire (-) of the LED control module to the black or blue wire (-) of the power supply.
- 7 Connect each LED control module output lead pair to each Tetra LED module supply lead pair using UL certified wire connectors. Cap each unused output lead with a UL certified wire connector.  
**WARNING:** Do not connect outputs in series or parallel.

## Dip Switch Settings

- 8 Turn power off. Only the first position dip switch is enabled - the other five position switches are disabled.  
**NOTE:** For proper operation, verify that only the first position switch is set to the "ON" position.
- 9 Replace the dip switch cover and perform a quick test by turning the system on to ensure the channel letter LEDs are lit.

The following chart indicates the Tetra Strip load that can be placed on the Power Supply based on the character code on the LED and the dip switch setting chosen. For example, when the Tetra Strip is marked with the character code EB5, the "5" on the dip switch can be set to the ON position to achieve neon-equivalent performance. At this setting, the GECLPS5 power supply can support up to 64 ft. (19m) of the 6 LED per foot Tetra Strip. If you change the dipswitch setting and flip #4 switch to the ON position, the power supply can support up to 80 ft. (24m) of Tetra Strip. The footage guidelines vary based on the type of Tetra Strip being used. The charts below provide the total footage requirements for each Tetra Strip type. To determine the footage for each power supply bank, divide the total footage by four.

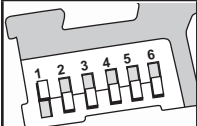
Loading Information			
Dip Switch Setting	GECLSPH Retrofit		Notes
	6 LEDs/ft. (20/m)	5 LEDs/ft. (16/m)	
	64 ft. (19.0m)	80 ft. (24.4m)	Recommended for Optimal Performance

**CAUTION:** Avoid setting the dip switch to the ON position with any setting not listed in the chart unless stated otherwise (i.e. Border Tube Installation). If these requirements are not followed, the Tetra Strip and Power Supply warranty will be void.

**NOTE:** Power off the LED control module when setting the dip switches.

**NOTE:** Do not connect outputs in series or parallel.

**NOTE:** When installing power supply, connect to the appropriate sized building breaker or disconnect device for line and neutral connections, in accordance with local, state or country regulations.

**NOTE:** The grounding and bonding of the power supply and overall sign shall be done in accordance with National Electric Code (NEC) Article 600.

## Specifications

Performance Data	Min	Typical	Max
Input Voltage (VDC)	23	24	25
Input Current (A)	-	-	3
Output Voltage (VDC)	-	-	4.1
Output Current (ADC)	-	-	4.0
Output Power (W)	-	-	32.8
Environmental Operating Temperature Range	-40°C	+25°C	+55°C*
Environmental Humidity (non-condensing)	0%	-	95%
Environmental Storage Temperature Range	-40°C	-	+85°C
Dimensions	9.5 in. x 1.7 in. x 1.2 in. (241 mm x 43.2 mm x 30.5 mm)		

\* Maximum case temperature is 85°C

This product is intended to be used as a lamp control gear that is installed after the mains control switch.  
Conforms to the following standards:



[www.gelighting.com](http://www.gelighting.com)

GE and the GE Monogram are trademarks of the General Electric Company. All other trademarks are the property of their respective owners. Information provided is subject to change without notice. All values are design or typical values when measured under laboratory conditions. GE Lighting is a business of the General Electric Company. © 2016 GE.

SIGNXXX (Rev 11/04/16)  
GE2026-1818