



HF-Essential II for TL5/TL-D

HF-E II 418 TL-D 220-240V 50/60Hz

Essentially smart and reliable HF-Essential II is the most cost-effective solution for reliably operation of a fluorescent lamp. It is also the ideal entry-level product for electromagnetic system users who want to take advantage of the benefits provided by electronic ballasts. The cost-saving and reliable HF-Essential II is energy efficiency class A2, and its robust design meets all relevant international safety and performance standards. HF-Essential II is the ideal choice for a broad range of new construction and retrofit applications within the commercial sector, including general surface mounting and office lighting, parking garages, warehouses and other applications. The ballast is primarily designed for Indoor application. For outdoor application, the luminaire should be minimum Class II need to be sufficiently protected against water & dust. The installation should also be guard against any lightning surge or any other necessary electrical protection as deemed in such typical installation & application.

Product data

General Information		Electrical Performance	
Lamp Type	TL-D II	Power Factor 100% Load (Nom)	0.97
Number of Lamps	4 piece/unit	Preheat Time	1.4 s
Number of Products on MCB (16A Type B) (Nom)	16	Mains Voltage Performance (AC)	220-240V
Automatic Restart	Yes	Mains Voltage Safety (AC)	184-276V
		Earth Leakage Current (Max)	0.5 mA
		Inrush Current Width	0.37 ms
		Ballast Factor (Nom)	0.95
		Power Losses (Nom)	10.4 W
		Inrush Current Peak (Max)	20 A
		Efficiency at full load [%]	84.89999999999999 %
Operating and Electrical			
Input Voltage	220 to 240 V		
Input Frequency	50 to 60 Hz		
Operating Frequency (Nom)	52.3 kHz		
Crestfactor (Nom)	1.8		

HF-Essential II for TL5/TL-D

Wiring

Connector Type Input Terminals	Insert
Cable Capacity Output Wires Mutual (Max)	150 pF
Connector Type Output Terminals	Insert
Cable Length Hot Wiring	0.75 m
Wire Striplength	8.0-9.0 mm
Dual Fixture Master/Slave	Possible, lamp wires 0.75m max. length [Master/Slave operation possible]
Input Terminal Cross Section	0.50-1.50 mm ²
Output Terminal Cross Section	0.50-1.50 mm ²
Cable Capacity Cold Output Wires - Earth (Max)	150 pF
Cable Capacity Hot Output Wires - Earth (Max)	150 pF

System characteristics

Rated Ballast-Lamp Power	18 W
Lamp Power on TL-D	14.5/14.6/14.5/14.4 W

Temperature

T-Ambient (Max)	50 °C
T-Ambient (Min)	-10 °C
T-Storage (Max)	50 °C
T-Storage (Min)	-20 °C
T-Case Lifetime (Nom)	80 °C
T-Case Maximum (Max)	80 °C

Mechanical and Housing

Housing	L 211x40x28.7
---------	---------------

Emergency Operation

Nominal Light Output After 60 Seconds	100% of EBLF
Normal Operating Voltage (DC)	220-240 V
Battery Voltage Guaranteed Operation	176-275 V
Battery Voltage Guaranteed Ignition	186-275 V
Emergency Ballast Lumen Factor (EBLF) (Nom)	100 %
Nominal Light Output After 5 Seconds	50% of EBLF

Approval and Application

Energy Efficiency Index	A2
IP Classification	IP 20 [Ingress Protection 20]
EMI 9 kHz ... 30 MHz	EN55015
Vibration Standard	IEC60068-2-6_2007-Fc
Bumps Standard	IEC 60068-2-29 Eb
Approval Marks	CE marking CB Certificate KEMA Keur certificate RoHS Compliant
Hum And Noise Level	< 30 dB(A)

Product Data

Full product code	871829177060200
Order product name	HF-E II 418 TL-D 220-240V 50/60Hz
EAN/UPC - Product	8718291770602
Order code	913713041266
Numerator - Quantity Per Pack	1
Numerator - Packs per outer box	20
Material Nr. (12NC)	913713041266
Net Weight (Piece)	0.155 kg

Dimensional drawing

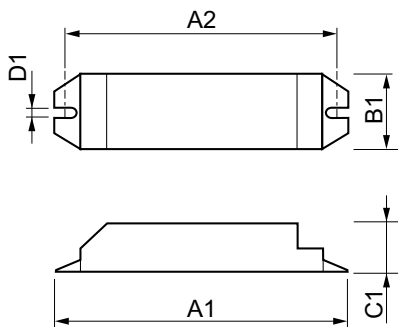

HF-E 418 TL-D II 220-240V 50/60Hz

Product	D1	C1	A1	A2	B1
HF-E II 418 TL-D 220-240V 50/60Hz	4.2 mm	28.7 mm	211.0 mm	198.0 mm	39.6 mm

HF-Essential II for TL5/TL-D

