



# HF-Regulator II for TL-D lamps

## HF-R 258 TL-D EII 220-240V 50/60Hz

High-frequency electronic dimming ballast, using the analog protocol (1-10 V) for TL-D lamps; The ballast is primarily designed for Indoor application. For outdoor application, the luminaire should be minimum Class II need to be sufficiently protected against water & dust. The installation should also be guard against any lightning surge or any other necessary electrical protection as deemed in such typical installation & application.

### Product data

General Information		Mains Voltage Safety (AC)	
Application Code	EII	Mains Voltage Safety (AC)	-10% - +10%
Type Version	mk2	Earth Leakage Current (Max)	0.5 mA
Lamp Type	TL-D	Inrush Current Width	0.40 ms
Number of Lamps	2 piece/unit	Power Losses (Nom)	11.2 W
Number of Products on MCB (16A Type B) (Nom)	12	Inrush Current Peak (Max)	45 A
Automatic Restart	Yes	<b>Wiring</b>	
Operating and Electrical		Connector Type Input Terminals	WAGO 251 universal connector [ Suitable for both automatic wiring (ALF and ADS) and manual wiring]
Input Voltage	220 to 240 V	Connector Type Output Terminals	WAGO 251 universal connector [ Suitable for both automatic wiring (ALF and ADS) and manual wiring]
Input Frequency	50 to 60 Hz	Connector Type Control Input Terminals	WAGO 251 universal connector [ Suitable for both automatic wiring (ALF and ADS) and manual wiring]
Operating Frequency (Max)	105 kHz	Wire Striplength	8.0-9.0 mm
Operating Frequency (Min)	45 kHz	Dual Fixture Master/Slave	- [ not specified]
Ignition Method	Programmed Start	Control Input Terminal Cross Section	0.50-1.00 mm <sup>2</sup>
Crestfactor (Max)	1.7		
Power Factor 100% Load (Nom)	0.98		
Ignition Time (Max)	0.2 s		
Mains Voltage Performance (AC)	-8% - +6%		

## HF-Regulator II for TL-D lamps

Input Terminal Cross Section	0.50-1.00 mm <sup>2</sup>
Output Terminal Cross Section	0.50-1.00 mm <sup>2</sup>
Auto Insert (ALF/ADS) Wire Cross Section	0.5 mm <sup>2</sup>
<b>System characteristics</b>	
Rated Ballast-Lamp Power	58 W
<b>Temperature</b>	
T-Ambient (Max)	50 °C
T-Ambient (Min)	10 °C
T-Storage (Max)	80 °C
T-Storage (Min)	-25 °C
Stable Lamp Operation Temperature	Not Specified
T-Ignition (Max)	50 °C
T-Ignition (Min)	0 °C
<b>Controls and Dimming</b>	
Control Interface	1-10V
Regulating Level Power	1%-100%
Control Input Protection	Yes (Basic insulation)
<b>Mechanical and Housing</b>	
Housing	L 360x30x21
<b>Emergency Operation</b>	
Battery Voltage Lamp Ignition	196 V
Battery Voltage Lamp Operation	154-276
<b>Approval and Application</b>	
Energy Efficiency Index	A1 BAT

IP Classification	IP 20 [ Ingress Protection 20]
EMI 9 kHz ... 30 MHz	EN55015
EMI 30 MHz ... 1000 MHz	EN55022 level B
Safety Standard	IEC 61347-2-3
Performance Standard	IEC 60929
Quality Standard	ISO 9000:2000
Environmental Standard	ISO 14001
Harmonic Current Emission Standard	IEC 61000-3-2
EMC Immunity Standard	IEC 61547
Vibration Standard	IEC68-2-6 F c
Bumps Standard	IEC 68-2-29 Eb
Humidity Standard	EN 61347-2-3 clause 11
Approval Marks	CE marking ENEC certificate VDE-EMV certificate
Temperature Marking	Yes
Emergency Standard	IEC 60598-2-22
Hum And Noise Level	Inaudible

### Product Data

Full product code	871150091019630
Order product name	HF-R 258 TL-D EII 220-240V 50/60Hz
EAN/UPC - Product	8711500910196
Order code	913700609566
Numerator - Quantity Per Pack	1
Numerator - Packs per outer box	12
Material Nr. (12NC)	913700609566
Net Weight (Piece)	0.325 kg

### Dimensional drawing

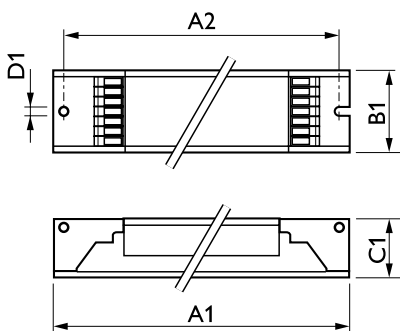

HF-R 258 TL-D EII 220-240V 50/60Hz

Product	D1	C1	A1	A2	B1
HF-R 258 TL-D EII 220-240V 50/60Hz	4.2 mm	22 mm	360 mm	350 mm	30 mm

## HF-Regulator II for TL-D lamps

