



HF-Selectalume II for TL-D lamps

HF-S 118/136 TL-D II 220-240V 50/60Hz

HF-Selectalume II is the most cost-effective, reliable, slim and affordable fluorescent solution, with highly disruptive technology for energy saving, system flexibility and unsurpassed performance. The cost-saving HF-Selectalume II has a robust design which meets all relevant international safety and performance standards. HF-Selectalume II is intended for use with indoor lighting fixtures such as spotlights, downlights and recessed luminaires, which are largely used in office, retail, industry, hotel, restaurant and other applications where control devices are installed with occasional On/Off switching activity

Product data

General Information	
Application code	II
Type version	mk1
Lamp type	TL-D
Number of lamps	1 piece/unit
Number of products on MCB (16 A type B) (nom.)	28
Automatic restart	Yes
Operating and Electrical	
Input Voltage	220 to 240 V
Input frequency	50 to 60 Hz
Operating frequency (nom.)	45 kHz
Crest factor (nom.)	1.7
Power factor 100% load (nom.)	0.98
Preheat time	1.6 s
Mains voltage performance (AC)	202-254V-8%-+6%

Mains voltage safety (AC)	198-264V-10%-+10%
Earth leakage current (max.)	0.5 mA
Inrush current width	0.35 ms
Ballast factor (nom.)	1.05
Power losses (nom.)	3.8 W
Inrush current peak (max.)	18 A
Wiring	
Connector type input terminals	WAGO 744 connector
Cable capacity output wires mutual (max.)	200 pF
Connector type output terminals	WAGO 744 connector [Suitable for manual wiring]
Cable length hot-wiring	0.75 m
Wire strip length	8.0-9.0 mm
Dual fixture master/slave	Possible, lamp wires 2m max. length [Master/Slave operation possible]
Input terminal cross section	0.50-1.50 mm ²

HF-Selectalume II for TL-D lamps

Output terminal cross section	0.50-1.50 mm ²
Cable capacity cold output wires – earth (max.)	200 pF
Cable capacity hot output wires – earth (max.)	200 pF

System characteristics

Rated ballast-lamp power	36 W
Rated lamp power on TL-D	36 W
System power on TL-D	38.8 W
Lamp power on TL-D	35 W
Power loss on TL-D	3.8 W

Temperature

T-ambient (max.)	55 °C
T-ambient (min.)	-20 °C
T storage (max.)	80 °C
T storage (min.)	-40 °C
T-case lifetime (nom.)	75 °C
T-Case maximum (max.)	75 °C

Mechanical and Housing

Housing	L 280x30x28
---------	-------------

Emergency Operation

Nominal light output after 60 seconds	100% of EBLF
Normal operating voltage (DC)	220-240 V
Battery voltage guaranteed operation	176-275 V
Battery voltage guaranteed ignition	186-275 V

Emergency ballast lumen factor (EBLF) (nom.)	100 %
Nominal light output after 5 seconds	50% of EBLF

Approval and Application

Energy efficiency index	A2 BAT
IP classification	IP 20 [Ingress Protection 20]
EMI 9 kHz ... 30 MHz	EN55015
Vibration standard	IEC68-2-6 F c
Bumps standard	IEC 68-2-29 Eb (10G/16ms)
Approval marks	F-Marking CE marking ENEC certificate CCC certificate C-Tick certificate PSB certification TISI marking SIRIM approval CB Certificate CCC certificate VDE-EMV certificate
Humming and noise level	< 30 dB(A)

Product Data

Full product code	872790090551900
Order product name	HF-S 118/136 TL-D II 220-240V 50/60Hz
EAN/UPC – product	8711500999290
Order code	913713032166
Local order code	HFS136TLDII
SAP numerator – quantity per pack	1
Numerator – packs per outer box	12
SAP material	913713032166
SAP net weight (piece)	0.200 kg

Dimensional drawing

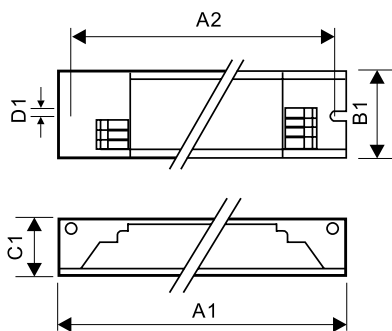

HF-S 136 TL-D II 220-240V 50/60Hz

Product

HF-S 118/136 TL-D II 220-240V 50/60Hz

HF-Selectalume II for TL-D lamps

