

1030QD, 1031QD, 1032QD and 1033QD Series Non-Relampable Neon Indicator Lights

Description and Features

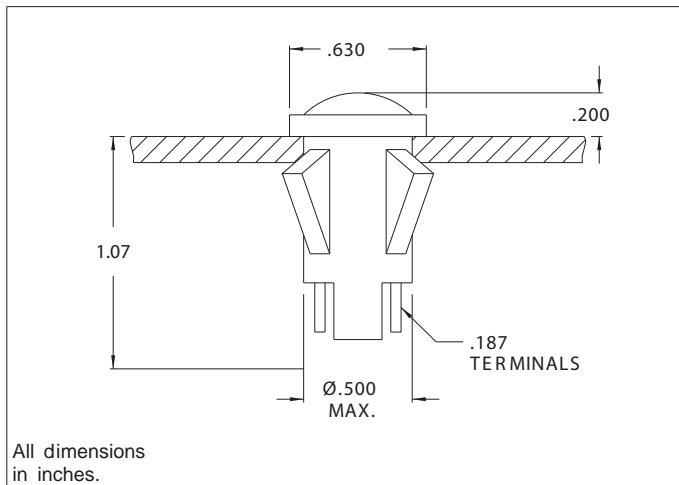

Mounting: Will snap-fit into Ø.500/.505 hole in panels .020/.100 thick. Push-on speednut SN0461 also available. Mounting hole pattern on page SP2.

Terminals: Quick-connect, tinned brass

Lens: Polycarbonate

Bezel: Polished stainless steel.

Housing: White Nylon

Lens Color	Neon	
	Model No. (105-125VAC)	Model No. (208-250VAC)
Red	1030QD1	1031Q D1
Amber	1030QD3	1031QD 3
White	1030QD4	1031QD 4
Green	1032QD5*	1033QD 5*
Lamp used	C2A+R esistor	

* Incorporates G2B lamp and resistor.
Underwriters Laboratories (UL) File No. E20356