

1050QA, 1051QA, 1052QA and 1053A Series Non-Relampable Neon Indicator Lights

Description and Features

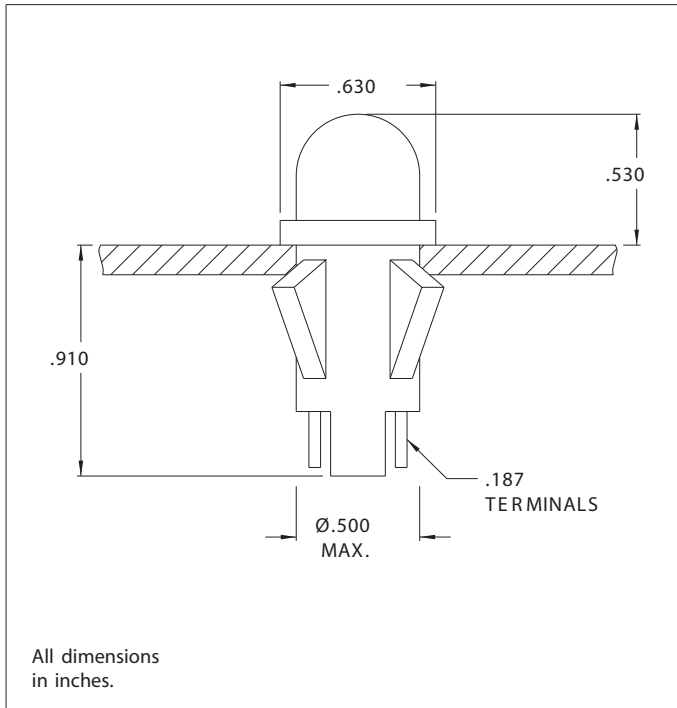

Mounting: Will snap-fit into Ø.500/.505 hole in panels .020/.100 thick. Push-on speednut SN0461 also available. Mounting hole pattern on page SP2.

Terminals: Quick-connect, tinned brass

Lens: Polycarbonate

Bezel: Polished stainless steel.

Housing: White Nylon

Lens Color	Neon	
	Model No. (105-125VAC)	Model No. (208-250V)
Red	1050QA1	1051QA1
Clear	1050QA2	-
Amber	1050QA3	1051QA3
White	1050QA4	1051QA4
Green	1052QA5*	1053QA5*
Blue	1052QA6**	1053QA6**
Lamp used	C2A+Resistor	
Quick Connect Terminals		

* Incorporates G2B lamp and resistor.

** Incorporates T2B lamp and resistor.

Underwriters Laboratories (UL) File No. E20356