

2150QA and 2151QA Series Non-Relampable Neon Indicator Lights

Description and Features

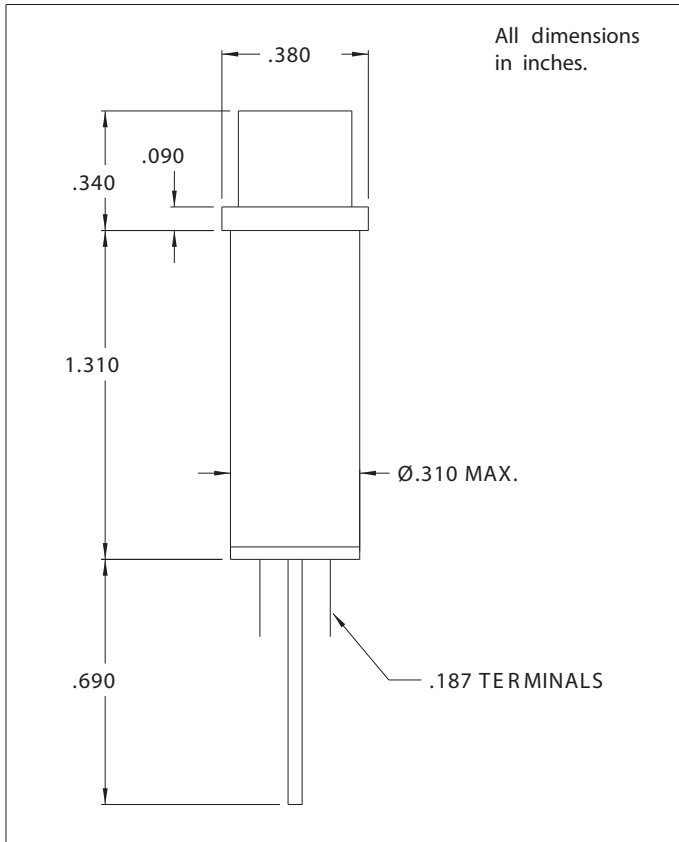

Mounting: Ø.310 MIN., supplied with push-on speednut SN1287.

Terminals: Quick-connect, tinned brass, .187 x .020

Lens: Polycarbonate

Bezel: Polished stainless steel.

Housing: White Nylon

Lens Color	Neon	
	Model No. (105-125VAC)	Model No. (208-250VAC)
Red	2150QA1	2151QA1
Amber	2150QA3	2151QA3
White	2150QA4	-
Green	2152QA5*	2153QA5*
Lamp	C2A+Resistor	C2A+Resistor

* Incorporates G2B lamp and resistor.
Underwriters Laboratories (UL) File No. E20356