

Recessed Double Contact Lampholders

For 800 and 1500mA Lamps



582.GDF™ & 583.GDF™ Series Lampholders

Completely isolates the face of the socket from ground. No metal clips means no corrosion or electrical grounding.

The Socket Sentry™ protective shield for lamp base and lampholder when installed on the bottom of a vertically installed T12 fluorescent lamp with a Kulka 582/583 Series lampholder will provide a shield of the lampglass, lampbase and lampholder electrical connection from water-spray, condensation, leakage and dust.

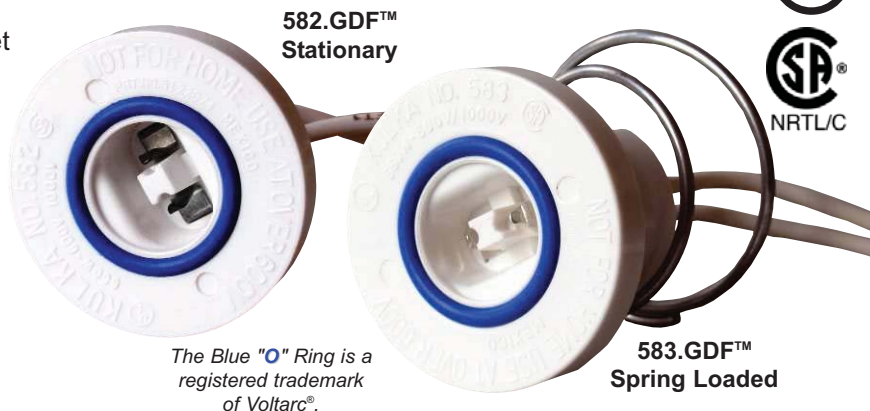

Specifications

Rating: 660 Watts, dual rated 600 V or 1000 V

Listing: UL File No. E-13408; CSA File No. LR95423.

UL listed and CSA certified for outdoor use in enclosed signs and fixtures.

Mounting: Snap-In, Dead Front Design

Materials

Housing: White urea

Contacts: Horizontal or vertical silver plated phosphor bronze, self wiping.

Mounting Clips: Fabulex™ Thermoplastic.

Gasket: Blue silicone treated neoprene "O" ring

Termination: Lead wires 9" (228.6 mm) long, 18 AWG stranded and tinned lead wires, 1/2" stripped, standard. Wire rated: AWM 1000V, 90°C (194°F).

582B Series Socket Sentry™ Protective Shield for Lamp Base Lampholder

Flammability

Rating: UL-94B

The Socket Sentry™ is intended to cover, not seal, the lampholder. The Socket Sentry™ should be replaced when relamping.



Part No.	Material	Service Temp.
582.BB	Black Neoprene	-65°F to +225°F
582.BS	Translucent Silicone	-180°F to +525°F

Socket Sentry™ is a trademark of Voltarc.
U.S. Patent No. 5,069,633.

Kulka® 582 / 583 Series

Spring Part No.	Stationary Part No.	
583.GDF	582.GDF	Snap-in mounting, 9" long leads with gasket and pitch
583.GDF-12	582.GDF-12	Snap-in mounting, 12" long lead with gasket and pitch
583.GDF-96*	582.GDF-96*	Snap-in mounting, 96" long leads
	582.GDF-A	Snap-in mounting, 9" long lead, self aligning
583.PDF	582.PDF	Snap-in mounting, 9" long leadwires with pitch only

*582.GDF/583.GDF Series packaged 250/box, except 582.GDF-96/583.GDF-96 packaged 100/box

Special lead wire lengths available upon request, consult sales department.

Options: Add Suffix "A": for Self Aligning Mounting Clip, Ideal for U-Lamp Applications

Add Suffix "SS" for Stainless Steel Spring

The Blue "O" Ring is a registered trademark of Voltarc®.
Dead Front Design US patent No. 5,122,074



Pitch to insulate electrical contacts (588.GDF™ back shown)

Mounting Panel Cutout
Recommended Panel Thickness
.031-.062"

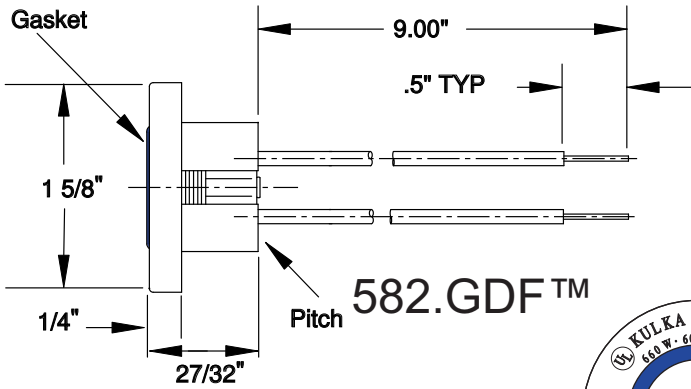
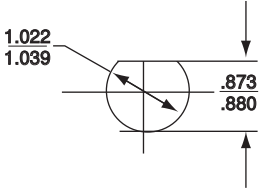

For U-Lamps
582GDF-A Self-Aligning

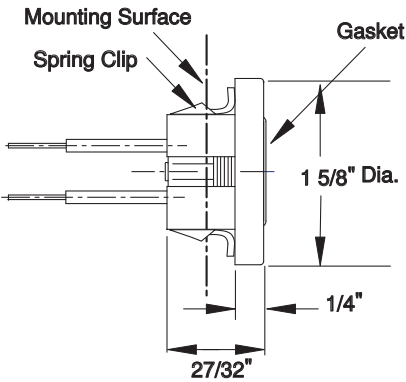

583.GDF™

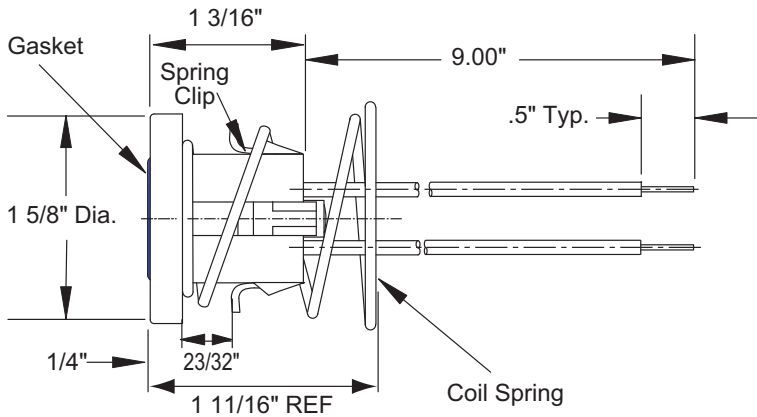

Panel to Panel Spacing

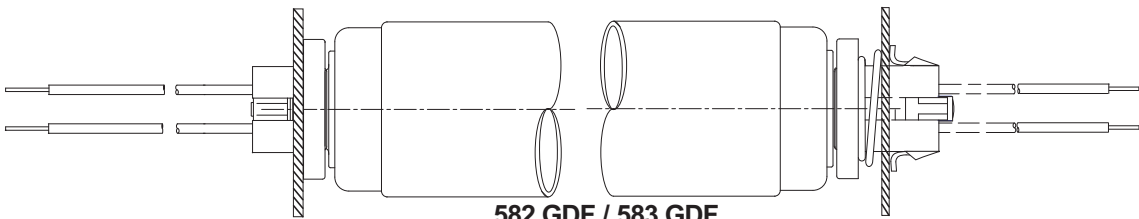

582.GDF / 583.GDF
Nominal Lamp LENGTH minus 1 3/4" ^{+1/16"} _{-1/32"}
582.GDF-A / 583.GDF
Nominal Lamp LENGTH minus 1 11/16" ^{+1/16"} _{-1/32"}

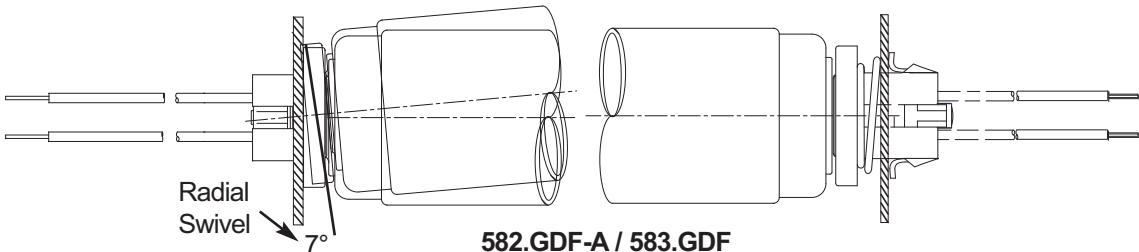

582.GDF-A / 583.GDF
Nominal Lamp LENGTH minus 1 19/32" ^{+1/16"} _{-1/32"}