

RedCap®

Emergency Lighting System

Energy Focus Installation Manual

Product Overview

Item #: LEDFLT8-8xx-4xx-BBUF

The RedCap® acts as both a normal lamp as well as emergency battery backup lamp for emergency egress lighting.

Direct Wire Mode: This product may be used as a direct-wire replacement of your current fluorescent tube. Rewiring your fixture, replacing lampholders and removal of ballast is required for this mode.

The “INPUT” end of the lamp, with white endcap, receives power from a standard MAINS power to operate the lamp in normal mode, typically controlled through a wall switch. The “EM INPUT” end of the lamp, with red endcap, is wired to “EMERGENCY MAINS,” power that is always on except during a power outage. The EM INPUT provides power to charge to the integrated battery. When power is present on the EM INPUT endcap, the lamp will act as a standard lamp. When emergency power is removed from the red endcap, the lamp will enter emergency mode, regardless of the state of the INPUT end. Note: both ends must be wired correctly for proper lamp function.

RedCap® Provides

- Aluminum heatsinks and integrated driver designed to retrofit T8 fluorescent lighting.
- Full brightness in automated switch-over to emergency mode with 1.5 hours minimum emergency run-time
- Test button and green LED indicator light to show operating status.
- Internal rechargeable lithium-ion battery
- Integrated battery charger and battery overcharge protection, over discharge protection, and short circuit protection
- Over 500 cycles of standard charge and discharge
- Universal Input Voltage of 100-277VAC (50/60 Hz).
- Three lamp color temperatures offered: 3500K, 4000K or 5000K.

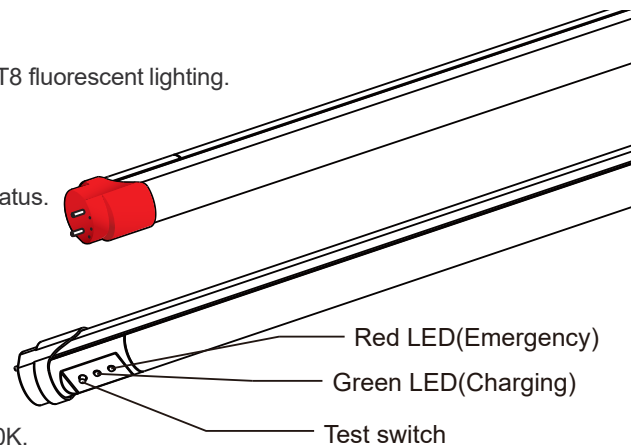

MODEL No.	Input Voltage	Power	Lumens	EM Lumens	Emergency Time	Color Temp	CRI
LEDFLT8-835-414-BBUF	100-277Vac, 50/60Hz	14W	1560 LM	960 LM	1.5Hr	3500K	>80
LEDFLT8-840-414-BBUF						4000K	
LEDFLT8-850-414-BBUF						5000K	

This manual provides information for the functionality and proper installation of the Energy Focus RedCap® Series Tubular LEDs (TLEDs). All servicing and installation of this product should be performed by qualified and authorized service personnel.

This product is intended to be used indoors, with closed type (diffuser or lens/cover) or open type, 4ft. fluorescent luminaires.

WARNING:

RISK OF FIRE OF ELECTRIC SHOCK.

Please read all instructions and warnings thoroughly before beginning install.

IMPORTANT: Customers are advised to charge emergency LED driver 24 hours every 6 months during storage

This product shall be installed in accordance with the latest NEC and/or local authority having jurisdiction. Installation shall be performed by a qualified electrician understanding the construction and operation of this product and the electrical requirements involved.

To prevent wiring damage or abrasion, do not expose wiring to edges of sheet metal or other sharp objects.

Safety

- **READ AND FOLLOW ALL SAFETY INSTRUCTIONS.**
- **ALWAYS DISCONNECT OR TERMINATE POWER TO LUMINAIRE PRIOR TO ANY INSTALLATION OR REPLACEMENT OF PRODUCT. Failure to do so may result in shock and/ or severe injury or damage to product. Always test circuits before installation with voltage tester. Standard MAINS and EMERGENCY MAINS may be provided by separate circuits.**
- The RedCap[®] LED Lamp is intended for use in dry locations only. Do not use outdoors.
- Do not allow lampholder supply wires to touch hot surfaces. Do not mount the Redcap[®] Lamp near gas or electric heaters. Equipment should be mounted in locations and at heights where it will not readily be subjected to tampering by unauthorized personnel. Max mounting height: 13ft.
- Do not use this equipment for other than its intended use. The use of accessory equipment not recommended by Energy Focus may cause an unsafe condition.
- The standby power ratings as labeled on this equipment describes power consumption at the Emergency Input end in watts when battery is charged and is not intended to describe total or maximum power consumption. Install this equipment only where the total power consumption does not exceed the input rating of the retrofitted luminaire in accordance with the National Electrical Code, ANSI/NFPA 70.
- Bypass, remove, and properly dispose of fluorescent ballast and fluorescent battery backup ballast.
- Do not make modifications to or alter luminaire housing, ballast enclosure, or electrical components other than those required for proper installation.
- **Included luminaire warning label must be affixed to luminaire in a visible location after installation near the red endcap. Included Lampholder caution label must be affixed next to the lampholder with EM INPUT battery charging power.**
- **The RedCap[®] Lamp will NOT operate with a dimmer switch.**
- Lamp contains lithium-ion rechargeable batteries and must be recycled or disposed of properly in accordance with local requirements.

FCC Verification

This device complies with Part 15 of the FCC Rules. Operation is subject to the following two conditions: (1) this device may not cause harmful interference, and (2) this device must accept any interference received, including interference that may cause undesired operation.

Warranty

- Visit energyfocus.com for full standard warranty terms and conditions.
- Please note that the warranty may not be valid in case of improper installation (for example, not turning off main power before installation), damage due to normal wear and tear, exceptional operational conditions, or unauthorized modifications.

This Package Includes:

- RedCap® LED lamp
- Luminaire warning label and Lampholder caution label
- Installation Instructions

Dimensions:

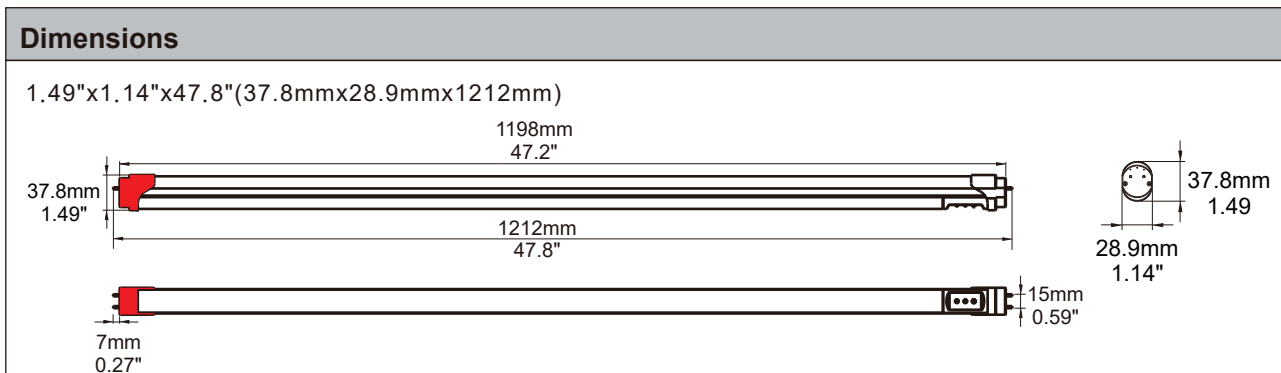

CAUTION:

- Please read this manual carefully before installing the RedCap® LED Lamp
- Turn OFF all AC Power before rewiring and installation.
- Ensure that L and N are properly connected to the Power Supplies.
- Affix included labels to luminaire as instructed. (See “SAFETY” section in this manual)
 - Included luminaire warning label must be affixed to luminaire in a visible location after installation near the red endcap.
 - Included Lampholder caution label must be affixed next to the lampholder with EM INPUT battery charging power.

Wiring Instructions:

- Note, this lamp requires two AC Line supplies. One switched line for normal lamp use, and one always ON connected to the Emergency End (EM) input of the lamp to recharge the lamp batteries. Turn OFF all AC Power before rewiring and installation.

Single Lamp Wiring Diagram:

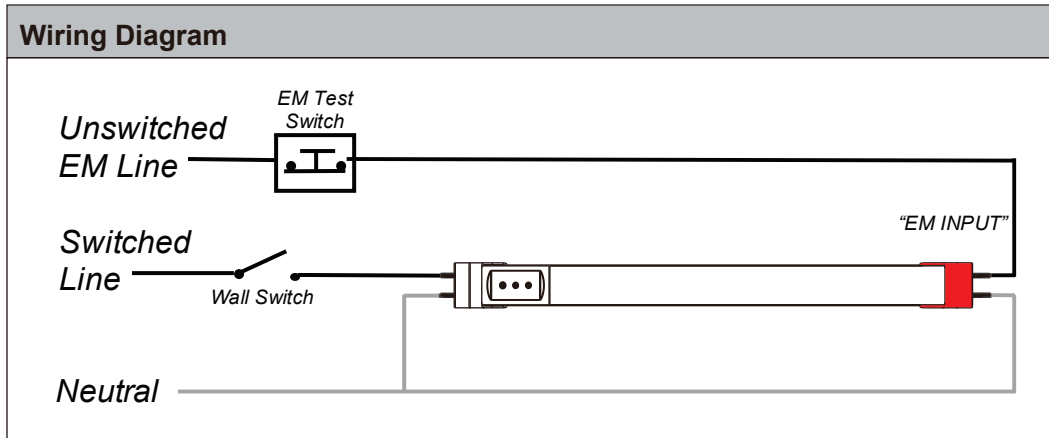

Multiple Lamp Wiring for Single End power lamps:

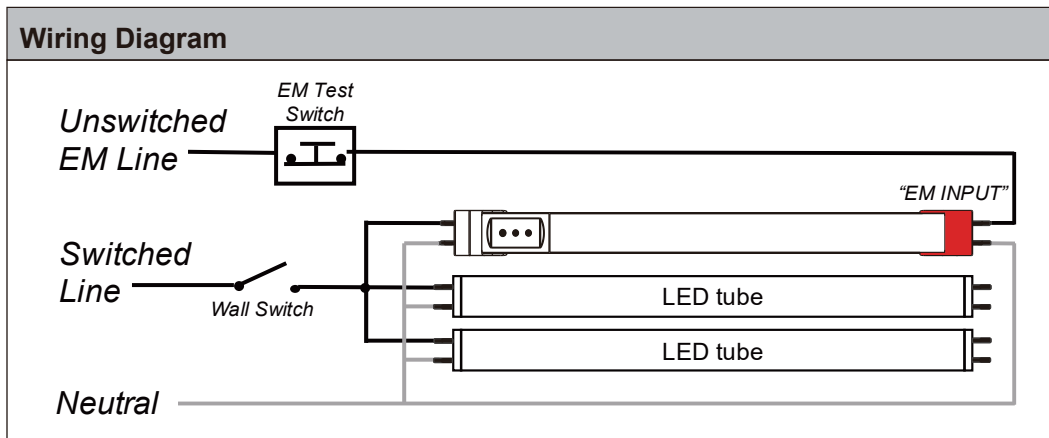

Multiple Lamp Wiring for Double End power lamps:

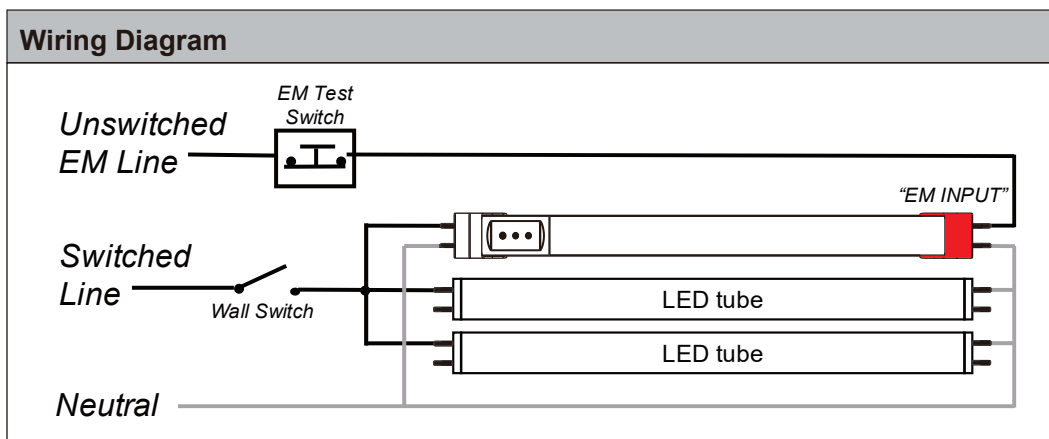

Operation:

The RedCap® LED lamp requires two AC Line supplies. One switched supply for normal lamp use, and one always 'ON' connected to the Emergency End input of the lamp, which will charge the battery. When power is cut to both ends, the lamp will remain fully illuminated for 90 minutes. The Green LED indicates that the lamp is charging. The Red Lamp indicates EM Mode is ON.

AC Operation

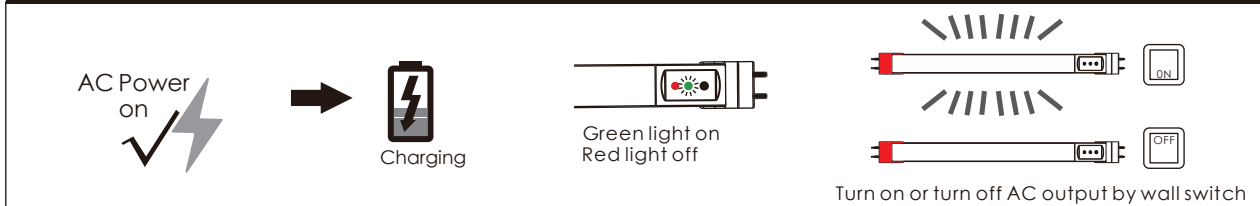

Emergency Operation

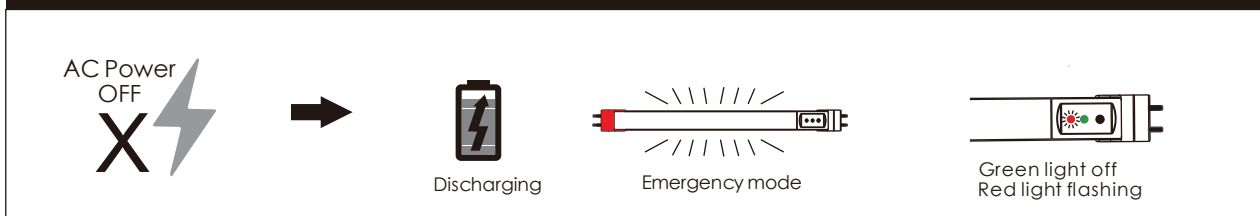

Testing:

- With the AC Power switched ON, push the test button once. The Green LED will turn OFF, and the Red LED will turn ON for 3 seconds. The Lamp will remain ON and will return to normal mode automatically.
- With AC Power OFF, push the button twice to turn EM Mode ON or OFF.

Button operation instructions

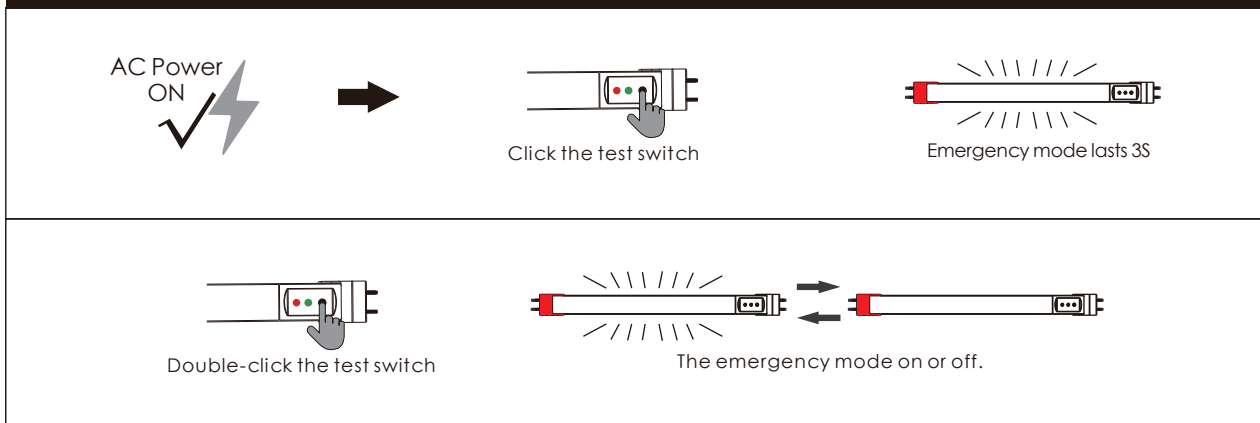

- Included Luminaire Warning label must be affixed to luminaire in a visible location after installation near the red endcap.
- Included Lampholder Caution label must be affixed next to the lampholder with EM INPUT battery charging power.

SAVE THESE INSTRUCTIONS.