



4 KV Pulse Rated Medium Base Porcelain Lampholders

HID & Incandescent Applications

White glazed porcelain body, copper alloy nickel-plated screw shell. Copper alloy nickel-plated center contact with leaf spring under contact. Standard leads: (1 black, 1 white) No. 18 ga. 200°C 600V SEW-2 (SF-2), 9" long, stripped 1/2".

Standard pack: bulk

Cat. Nos. 70045 & 70046 Series

- 660W-600V • 4 KV Pulse Rated • UL Listed E-3810 (70046 Series)
- UL Recognized Component  E-3810 (70045 Series)
- CSA Certified LR-1863 • NOM Certified 057



Cat. No. Bushing Mount	Cat. No. Screw Mount	With Screw Shell Reinforcing Washers	With Lamp Grip Screw Shell	Less Leaf Spring Under Center Contact
70045-000	70046-000	—	—	—
70045-001	70046-001	X	—	—
70045-002	70046-002	—	X	—
70045-003	70046-003	X	X	—
70045-010	70046-010	—	—	X
70045-011	70046-011	X	—	X
70045-012	70046-012	—	X	X
70045-013	70046-013	X	X	X

NOTE: Cat. Nos. 70045-500 and 70046-500 available. Same as Nos. 70045 and 70046, except 5 KV pulse-rated. UL Recognized Components.

Cat. No.	Terminations
18875	Screw terminals
18876	Standard leads No. 18 ga. 200°C 600V SEW-2 (SF-2), 9" long, stripped 1/2"
18877	1/4" wide quick-connect tabs

Snap-In Mounting

White unglazed porcelain body. Copper alloy screw shell.

Standard pack: bulk

Cat. Nos. 18875, 18876 & 18877

- 660W-600V • 4 KV Pulse Rated • UL Listed E-3810 • CSA Certified LR-1863

NOTE: Cat. No. 18876-500 lampholder available. 5 KV pulse rated for use with Philips White Son metal halide lamps. UL Recognized Component.

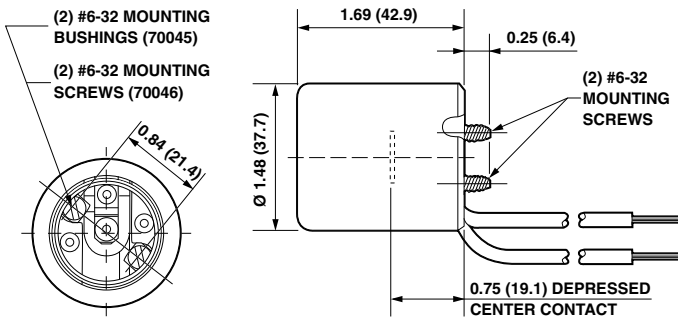

Cat. No. 70045/70046

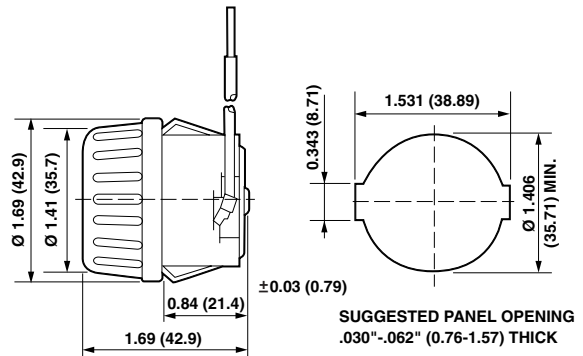

Cat. No. 18876