

# Porcelain Adapter

(Mogul Base E39-to-Medium Base E26)

One-piece, white glazed porcelain body. Aluminum screw shell.

**Standard pack:** bulk

**Cat. No. 8681**

• 660W-250V • UL Listed E-13396 • CSA Certified LR-1863

**Cat. No. 8681-400:** 4KV Version



# Phenolic Flanged Adapter

(Medium Base E26)

Phenolic body with standard male screw shell reinforced and eyeleted in place. Leads are No. 18 ga. 105°C AWM-TEW plastic insulated wire, 4 1/2" long, stripped 1/2" unless otherwise specified. Aluminum screw shell.

**Standard pack:** bulk

**Cat. No. 165**

**Cat. No. 165-001** Same as No. 165, less leads

**Cat. No. 165-P** Porcelain version available upon request

• 660W-250V • UL Recognized Component  E-13396

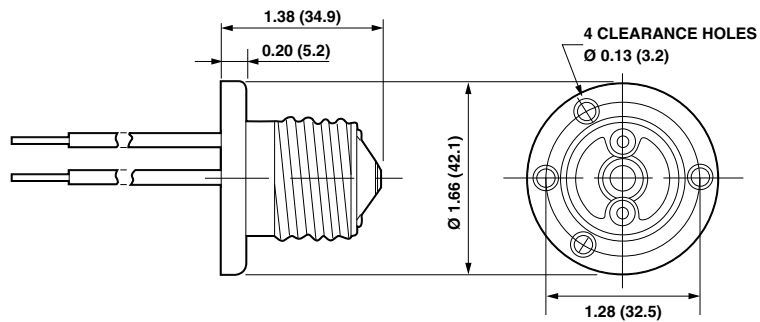

**Cat. No. 165**