

# Lumination® LED Luminaires

LED Recessed Luminaire  
LPL22 Value Series | Panel Light Gen D

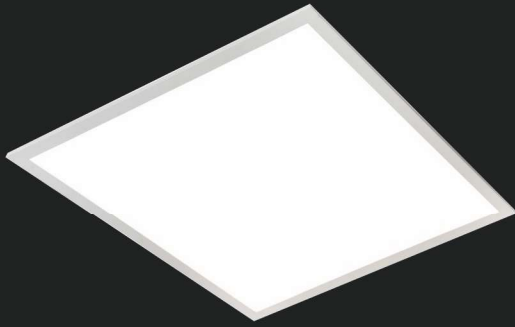

CUSTOMER NAME \_\_\_\_\_

Project Name \_\_\_\_\_

Date \_\_\_\_\_ Type \_\_\_\_\_

Catalog Number \_\_\_\_\_

## Ideal for commercial ceilings with T-grid layouts.

- Field switchable 2400/3750/4350 lm@3500K
- Fits standard T-Bar grid (drop ceilings)
- IC rated and Chicago Plenum (CCEA)

## Options include:

- ISO 4 cleanroom rated
- Integral Daintree® Sensor

## ProLine®

### CONSTRUCTION

<b>Housing:</b>	Durable, long lasting steel construction. Aluminum extruded frame
<b>Lens:</b>	Precision formed optical assembly
<b>Paint:</b>	Post painted powder coat finish
<b>Weight:</b>	7.7 pounds

### OPTICAL SYSTEM

<b>Lumens:</b>	2400/3750/4350 Lumens@3500K (Field Switchable)
<b>Wattage:</b>	21.5/34/39.5W (Field Switchable)
<b>Efficacy:</b>	Up to 124 LPW
<b>CCT:</b>	3500K, 4000K, 5000K (Field Switchable)
<b>CRI:</b>	80+, R9 >0

### ELECTRICAL

<b>Input Voltage:</b>	120–277V
<b>Input Frequency:</b>	50/60Hz
<b>Standard Dimming Control:</b>	0–10V, Dimming
<b>Power Factor (PF)*:</b>	>0.9
<b>Total Harmonic Distortion (THD)*:</b>	<20%

\* PF and THD may vary with options

### CONTROLS

<b>Dimming:</b>	Standard: 0–10V, Dimming
<b>Sensors:</b>	Daintree® Wireless, with high-end trim

### LUMEN AMBIENT TEMPERATURE

TYPE	TEMPERATURE RATE
OPERATING TEMPERATURE	0°C TO +40° C
STORAGE TEMPERATURE	-40°C TO +70°C

### LUMEN MAINTENANCE

L85 @ 60,000 Hours
L85

### MOUNTING

- **Typical Mounting:** Fits standard T-Bar grid (drop ceilings)
- **Wiring Access:** ½" trade-size KOs
- **T-grid Clips:** T-grid clips attached, with holes for seismic wires
- **Surface Mounting:** Surface mount kit available

### DESIGN LIFE & WARRANTY

- Damp Location rated
- IC rated and Chicago Plenum (CCEA)
- UL/cUL Listed
- RoHS compliant
- ANSI C82.77 Compliant
- Option of ISO 4 rated under positive and negative pressure
- **Current's Limited 5-year Warranty:**  
Please refer to document [IND599](#) for more information.

# Lumination® LED Luminaires

LED Recessed Luminaire  
LPL22 Value Series | Panel Light Gen D  
*Catalog Logic and Accessories*

## CUSTOMER NAME

Project Name \_\_\_\_\_

Date \_\_\_\_\_ Type \_\_\_\_\_

Catalog Number \_\_\_\_\_

## Ordering Information<sup>1</sup> (Important: Please see note 1 below):

**LPL 22 D 0 3X MM 8XX**      **LT WHITE**

FAMILY	FIXTURE TYPE	GENERATION	VOLTAGE	NOMINAL LUMENS	DISTRIBUTION	CRI/CCT	CONTROLS	MOUNTING	FINISH	OPTIONS
LPL = Proline® Panel Light	22 = 2' x 2'	D = 4 <sup>th</sup> Generation	0 = 120-277V	3X = Nominal Lumen Level (middle is default)	MM = Med. Lambertain	8 = 80 CRI 3500/4000/5000K Switchable (4000K is default)	VQ = 0-10V Dimming TE = Daintree® EZ Connect Non-Upgradable, WIT100	LT= T-Grid	WHITE = White	C4 <sup>4,5,6</sup> = ISO 4 rated <i>All options are sold separately as accessories, please see below.</i>

### ORDERING NOTES:

- ALL LPL UNITS ARE PRICED AS SINGLE UNITS AND MUST BE ORDERED AS SINGLE UNITS IN EVEN QUANTITIES AS THIS PRODUCT IS PACKED TWO PER BOX. IT SHOULD BE NOTED IN RECEIVING DOCUMENTS THAT ONE BOX HAS TWO UNITS AND SHOULD BE RECEIVED AS TWO UNITS.
- All options are accessories that are quickly and easily attached and/or wired to the luminaire in the field by the installer.
- Fixture is field configurable for three different lumens and CCT levels with switches. Switch defaults are the middle level (4100 lumens @34w and 4000K).
- ISO rated fixtures must be installed per manufacturer's instructions to maintain ISO rating.
- ISO rated fixtures available as factory supplied option.
- ISO option for recessed fixtures only, for drywall applications consult factory.

**QuickShip**

EXAMPLE CONFIGURATIONS	LUMINAIRE LUMENS (SWITCHABLE <sup>3</sup> )	LUMINAIRE TOTAL SYSTEM WATTS	LUMINAIRE CCT (SWITCHABLE <sup>3</sup> )	LPW	ONE WEEK 1-100 UNITS
LPL22D03XMM8XXVQLTWHITE	2400/3750/4350	21.5/34/39.5W	3500K/ 4000K/ 5000K	> 110	YES
LPL22D03XMM8XXTELTWHITE	2400/3750/4350	21.5/34/39.5W	3500K/ 4000K/ 5000K	> 110	YES

## ACCESSORIES

ACCESSORIES	DESCRIPTION CODE	PRODUCT CODE
Drywall Mount Kit 2x2	GESK07	67657
2x2 Surface Mount Kit for Backlit T-Grid Suitable for Lumination troffers & panels Height = 4.95 Inches (see dimensions section on next page)	B22 SMK	212462
2x2 Flat Panel Surface Mount Kit Suitable for LPL Gen D standard fixture only. Not compatible with any options or other field installable kits Height = 2.5 Inches (see dimensions section on next page)	PSMK-22	93302544
347V kit	LFAMBADVQFA GEN D	93302219
EMBB kit Provides 90 minutes of emergency lighting	LFAMBAOVQFAEL GEN D	93302218
Wireless Enabled, Daintree® Compatible with Daintree® WFA 100 + Emergency Bypass kit (Dual Shunt Relay to be used with building generator backup systems to override dimming—Contact manufacturer prior to ordering to confirm application)	LCAMBA0T5FAB2	93071582

# Lumination® LED Luminaires

LED Recessed Luminaire  
LPL22 Value Series | Panel Light Gen D

## Dimensions & Photometrics

### CUSTOMER NAME

Project Name \_\_\_\_\_

Date \_\_\_\_\_ Type \_\_\_\_\_

Catalog Number \_\_\_\_\_

### PRODUCT & ACCESSORY DIMENSIONS

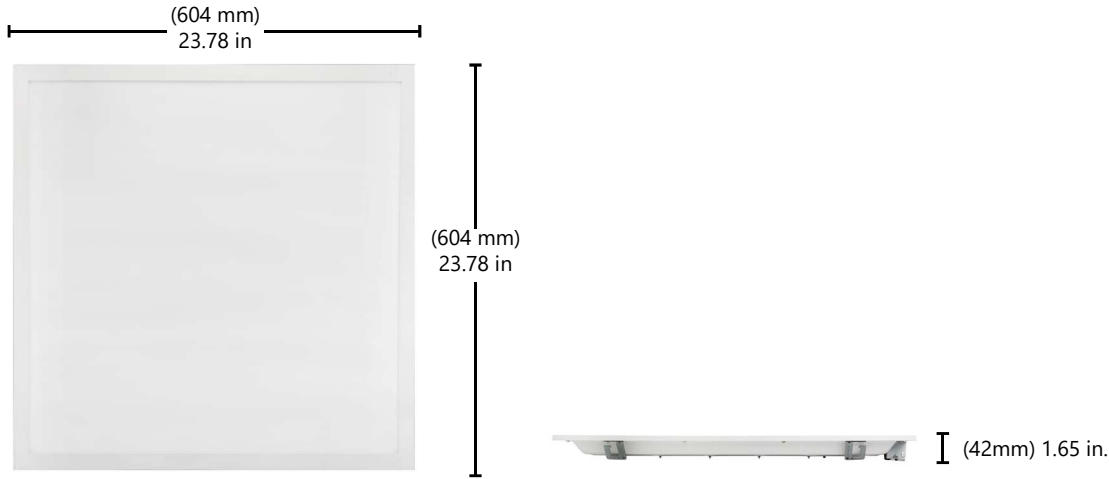

### SURFACE MOUNT KIT DIMENSIONS

#### B22 SMK

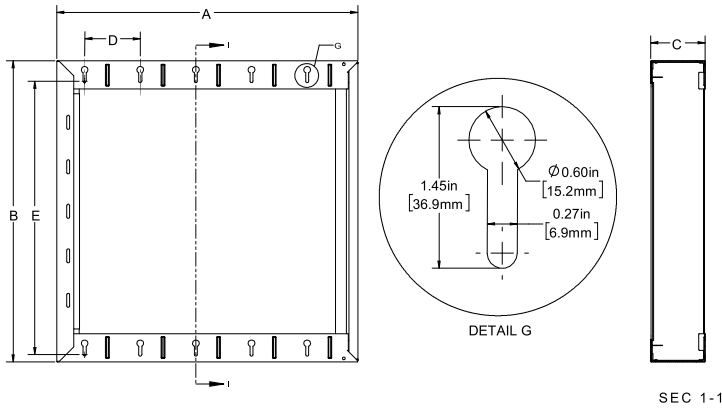

#### PSMK-22

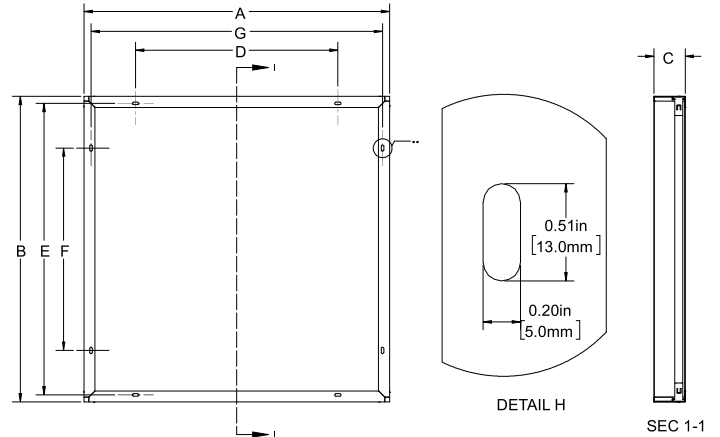

Product Code	Description	A (in)	B (in)	C (in)	D (in)	E (in)	Key Hole Qty Upper/lower side
212462	B22 SMK	27.08	27.08	4.95	5.0	24.6	5
212463	B24 SMK	27.08	51.08	4.95	5.0	48.6	5

Product Code	Description	A (in)	B (in)	C (in)	D (in)	E (in)	F (in) Between Holes	G (in)
93302543	PSMK-14	12.05	48.0	2.5	1 hole	46.88	16.0 (3 holes)	10.92
93302544	PSMK-22	24.16	24.16	2.5	16.0	23.06	16.0	23.06
93302545	PSMK-24	24.16	48.0	2.5	16.0	46.88	16.0 (3 holes)	23.06

# Lumination® LED Luminaires

LED Recessed Luminaire  
LPL22 Value Series | Panel Light Gen D

## Controls and Sensors

### CUSTOMER NAME

Project Name \_\_\_\_\_

Date \_\_\_\_\_ Type \_\_\_\_\_

Catalog Number \_\_\_\_\_

## PHOTOMETRICS (3750LM@3500K)

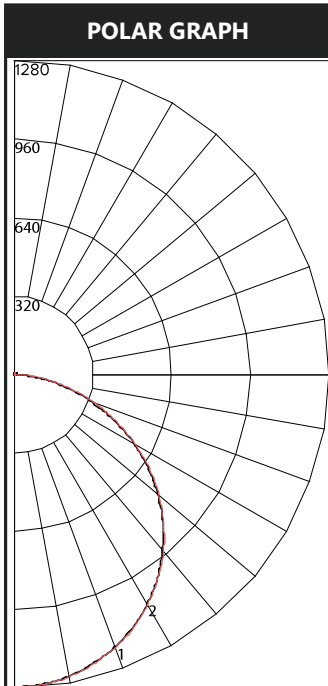

ZONAL LUMEN SUMMARY	
Zone	Lumens
0-10	121.09
10-20	348.11
20-30	530.95
30-40	644.69
40-50	672.99
50-60	611.15
60-70	467.21
70-80	270.07
80-90	77.12
90-100	0.96
100-110	0.69
110-120	0.79
120-130	0.93
130-140	0.98
140-150	0.91
150-160	0.74
160-170	0.52
170-180	0.18

## DAINTREE CONTROLS

### Daintree® Wireless Controls:

There is no one size fits all for wireless controls. Some networks want simple solutions that reduce energy consumption and meet code compliance while others are more ambitious, looking to capitalize on the LED and controls savings to fund a scalable, enterprise-grade, internet of things solution. The advantage of the Daintree® Wireless platform is its ability to integrate into indoor, outdoor and high bay environments. The Daintree® Wireless Controls provide the infrastructure to future proof your buildings, easily upgrade to Networked solutions and provide the ability to integrate into IoT solutions that are right for your business.

- **Daintree® One:** Standalone Wireless Controls
- **Daintree® EZ Connect:** Room-Based Wireless Lighting Controls
- **Daintree® Networked:** Networked Lighting Controls for Smart Building & IoT Enablement

Daintree® Wireless Controls are already integrated in your favorite Current LED fixtures. Integrating the controls into the fixture cuts labor costs considerably since the sensors are already embedded in the lighting fixtures. There's no need to get above the ceiling plenum and install additional devices. Visit our website <https://products.gecurrent.com> for a complete list of LED Fixtures.

### For Product or Technical Questions:

Email: [lightingproinfo@gecurrent.com](mailto:lightingproinfo@gecurrent.com)

Phone: +1 888 694 3533, option 2



## ProLine®

Every contractor deserves a  
Fast, Reliable, and Trusted Lighting Partner