

Cree® LMH2 LED Modules Family

LMH2 Light Source with Flat Lens



LMH2 Light Source with Dome Lens



PRODUCT DESCRIPTION

Cree LED modules provide lighting designers and manufacturers with simple, easy-to-adopt LED lighting solutions that reduce luminaire development time and speed time-to-market. Cree LMH2 family LED modules are the ideal choice for enabling rapid luminaire development where bright, beautiful, long-life lighting is required. The ease of use of the LMH family enables this versatile LED lighting module to jump-start the design process for recessed downlights, wall sconces or pendant lights in demanding end markets such as retail, museums and studio lighting.

FEATURES

- Industry-leading light-source efficacy (steady state) of up to 97 lm/W for 850-3000 lm, 108 lm/W for 4000 lm, 85 lm/W for 6000 & 8000 lm LMH2, 125 lm/W for 1250-3000 lm LMH2+
- 850-4000 lm available in 2700 K, 3000 K, 3500 K and 4000 K CCT
- 4000 lm & 6000 lm available in 5000 K
- 6000 lm & 8000 lm available in 3000 K, 3500 K and 4000 K CCT
- ≥ 90 CRI for all CCTs
- Minimum 95 CRI available for 3500 K at 3000 lm
- Industry-leading 5-year warranty
- Designed to last 50,000 hours at L_{70}
- No UV in light output
- No mercury in light source

TABLE OF CONTENTS

LMH2 Characteristics	2
LMH2 Order Codes - 90 CRI Minimum	3
LMH2 Order Code - 95 CRI Minimum	3
LMH2+ Characteristics	4
LMH2+ Order Codes	5
Thermal Management Guidelines	6
Relative Spectral Power Distribution	7
Relative Luminous Flux vs. Case Temperature	9
Typical Voltage vs. Case Temperature	11
Relative Luminous Flux vs. Current	13
Photometry	14
Performance Groups - Chromaticity	17
Chromaticity Bins Plotted on the 1931 CIE Color Space	18
Mechanical Dimensions	19
Notes	20
Packaging	20

LMH2 CHARACTERISTICS* (T_c = 55 °C)

Characteristics	Unit	Minimum	Typical	Maximum
Viewing angle (FWHM) - 850- & 1250-lm flat lens	degrees		82	
Viewing angle (FWHM) - 850- & 1250-lm dome lens	degrees		96	
Viewing angle (FWHM) - 2000- & 3000-lm flat lens	degrees		82	
Viewing angle (FWHM) - 2000- & 3000-lm dome lens	degrees		105	
Viewing angle (FWHM) - 4000-lm flat lens	degrees		85	
Viewing angle (FWHM) - 4000-lm dome lens	degrees		105	
Viewing angle (FWHM) - 6000-lm flat lens	degrees		86	
Viewing angle (FWHM) - 6000-lm dome lens	degrees		110	
Viewing angle (FWHM) - 8000-lm flat lens	degrees		84	
Viewing angle (FWHM) - 8000-lm dome lens	degrees		110	
DC forward current - 850 & 1250 lm	mA	400	440	480
DC forward current - 2000 & 3000 lm	mA	810	900	990
DC forward current - 4000 lm	mA	850	940	1030
DC forward current - 6000 lm	mA	1530	1700	1870
DC forward current - 8000 lm	mA	1800	2000	2100
Forward voltage - 850 lm (@ 440 mA, 55 °C)	V		19	23
Forward voltage - 1250 lm (@ 440 mA, 55 °C)	V		29	34
Forward voltage - 2000 lm (@ 900 mA, 55 °C)	V		22	26
Forward voltage - 3000 lm (@ 900 mA, 55 °C)	V		33	38
Forward voltage - 4000 lm (@ 940 mA, 55 °C)	V		35.5	43
Forward voltage - 6000 lm (@ 1700 mA, 55 °C)	V		38	46
Forward voltage - 8000 lm (@ 2000 mA, 55 °C)	V		46.2	52
Luminous flux - 850-lm (@ 440 mA, 55 °C)	lm	790	850	909
Luminous flux - 1250-lm (@ 440 mA, 55 °C)	lm	1163	1250	1337
Luminous flux - 2000-lm (@ 900 mA, 55 °C)	lm	1860	2000	2140
Luminous flux - 3000-lm (@ 900 mA, 55 °C)	lm	2790	3000	3210
Luminous flux - 4000-lm (@ 940 mA, 55 °C)	lm	3720	4000	4280
Luminous flux - 6000-lm (@ 1700 mA, 55 °C)	lm	5580	6000	6420
Luminous flux - 8000-lm (@ 2000 mA, 55 °C)	lm	7440	8000	8560
LED module case temperature (T _c)	°C	0		70
CRI - 90 CRI	100-point scale	90	92	
CRI - 95 CRI	100-point scale	95		

Notes:

- LMH2 modules are not designed for reverse bias operation.
- Cree maintains a tolerance of $\pm 7\%$ on flux measurements, $\pm 10\%$ on power measurements, ± 0.005 on chromaticity (CC_x, CC_y) measurements and a tolerance of ± 2 on CRI measurements.
- 55 °C measured at case temperature (T_c) point shown on page 19.
- Luminous flux values for the dome lens LMH2 LED module can be up to 3% higher.
- * Provides consistent color across the entire dimming range.

LMH2 ORDER CODES - 90 CRI MINIMUM

Typical Luminous Flux (lm)	Typical Light Source Efficacy (lm/W)	CCT (K)	Order Code	
			Flat Lens	Dome Lens
850	97	4000	LMH020-0850-40G9-00000TW	LMH020-0850-40G9-00001TW
		3500	LMH020-0850-35G9-00000TW	LMH020-0850-35G9-00001TW
		3000	LMH020-0850-30G9-00000TW	LMH020-0850-30G9-00001TW
		2700	LMH020-0850-27G9-00000TW	LMH020-0850-27G9-00001TW
1250	97	4000	LMH020-1250-40G9-00000TW	LMH020-1250-40G9-00001TW
		3500	LMH020-1250-35G9-00000TW	LMH020-1250-35G9-00001TW
		3000	LMH020-1250-30G9-00000TW	LMH020-1250-30G9-00001TW
		2700	LMH020-1250-27G9-00000TW	LMH020-1250-27G9-00001TW
2000	97	4000	LMH020-2000-40G9-00000TW	LMH020-2000-40G9-00001TW
		3500	LMH020-2000-35G9-00000TW	LMH020-2000-35G9-00001TW
		3000	LMH020-2000-30G9-00000TW	LMH020-2000-30G9-00001TW
		2700	LMH020-2000-27G9-00000TW	LMH020-2000-27G9-00001TW
3000	97	4000	LMH020-3000-40G9-00000TW	LMH020-3000-40G9-00001TW
		3500	LMH020-3000-35G9-00000TW	LMH020-3000-35G9-00001TW
		3000	LMH020-3000-30G9-00000TW	LMH020-3000-30G9-00001TW
		2700	LMH020-3000-27G9-00000TW	LMH020-3000-27G9-00001TW
4000	108	5000	LMH020-4000-50G9-00000TW	LMH020-4000-50G9-00001TW
		4000	LMH020-4000-40G9-00000TW	LMH020-4000-40G9-00001TW
		3500	LMH020-4000-35G9-00000TW	LMH020-4000-35G9-00001TW
		3000	LMH020-4000-30G9-00000TW	LMH020-4000-30G9-00001TW
		2700	LMH020-4000-27G9-00000TW	LMH020-4000-27G9-00001TW
6000	85	5000	LMH020-6000-50G9-00000TW	LMH020-6000-50G9-00001TW
		4000	LMH020-6000-40G9-00000TW	LMH020-6000-40G9-00001TW
		3500	LMH020-6000-35G9-00000TW	LMH020-6000-35G9-00001TW
		3000	LMH020-6000-30G9-00000TW	LMH020-6000-30G9-00001TW
8000	85	4000	LMH020-8000-40G9-00000TW	LMH020-8000-40G9-00001TW
		3500	LMH020-8000-35G9-00000TW	LMH020-8000-35G9-00001TW
		3000	LMH020-8000-30G9-00000TW	LMH020-8000-30G9-00001TW

LMH2 ORDER CODE - 95 CRI MINIMUM

Typical Luminous Flux (lm)	Typical Light Source Efficacy (lm/W)	CCT (K)	Order Code
			Flat Lens
3000	97	3500	LMH020-3000-35GS-00000TW

LMH2+ CHARACTERISTICS* (T_c = 55 °C)

Characteristics	Unit	Minimum	Typical	Maximum
Viewing angle (FWHM) - 1250-lm flat lens	degrees		82	
Viewing angle (FWHM) - 1250-lm dome lens	degrees		96	
Viewing angle (FWHM) - 2000-lm flat lens	degrees		82	
Viewing angle (FWHM) - 2000-lm dome lens	degrees		105	
Viewing angle (FWHM) - 3000-lm flat lens	degrees		82	
Viewing angle (FWHM) - 3000-lm dome lens	degrees		105	
DC forward current - 1250 lm	mA		450	750
DC forward current - 2000 lm	mA		450	940
DC forward current - 3000 lm	mA		600	1000
Forward voltage - 1250 lm (@ 450 mA, 55 °C)	V		22.5	25
Forward voltage - 2000 lm (@ 450 mA, 55 °C)	V		35	38.5
Forward voltage - 3000 lm (@ 600 mA, 55 °C)	V		40	44
Luminous flux - 1250-lm (@ 450 mA, 55 °C)	lm	1163	1250	1337.5
Luminous flux - 2000-lm (@ 450 mA, 55 °C)	lm	1860	2000	2140
Luminous flux - 3000-lm (@ 600 mA, 55 °C)	lm	2790	3000	3210
LED module case temperature (T _c)	°C	0		70
CRI	100-point scale	90	92	

Notes:

- LMH2+ modules are not designed for reverse bias operation.
- Cree maintains a tolerance of ±7% on flux measurements, ±10% on power measurements, ±0.005 on chromaticity (CC_x, CC_y) measurements and a tolerance of ±2 on CRI measurements.
- 55 °C measured at case temperature (T_c) point shown on page 19.
- Luminous flux values for the dome lens LMH2+ LED module can be up to 3% higher.
- * Provides consistent color across the entire dimming range.

LMH2+ ORDER CODES

Typical Luminous Flux (lm)	Typical Light Source Efficacy (lm/W)	CCT (K)	Order Code	
			Flat Lens	Dome Lens
1250	125	4000	LMH02B-1250-40G9-00000TW	LMH02B-1250-40G9-00001TW
		3500	LMH02B-1250-35G9-00000TW	LMH02B-1250-35G9-00001TW
		3000	LMH02B-1250-30G9-00000TW	LMH02B-1250-30G9-00001TW
		2700	LMH02B-1250-27G9-00000TW	LMH02B-1250-27G9-00001TW
2000	125	4000	LMH02B-2000-40G9-00000TW	LMH02B-2000-40G9-00001TW
		3500	LMH02B-2000-35G9-00000TW	LMH02B-2000-35G9-00001TW
		3000	LMH02B-2000-30G9-00000TW	LMH02B-2000-30G9-00001TW
		2700	LMH02B-2000-27G9-00000TW	LMH02B-2000-27G9-00001TW
3000	125	4000	LMH02B-3000-40G9-00000TW	LMH02B-3000-40G9-00001TW
		3500	LMH02B-3000-35G9-00000TW	LMH02B-3000-35G9-00001TW
		3000	LMH02B-3000-30G9-00000TW	LMH02B-3000-30G9-00001TW
		2700	LMH02B-3000-27G9-00000TW	LMH02B-3000-27G9-00001TW

MECHANICAL DIMENSIONS²

LMH2 Family Light Source (Flat Lens)

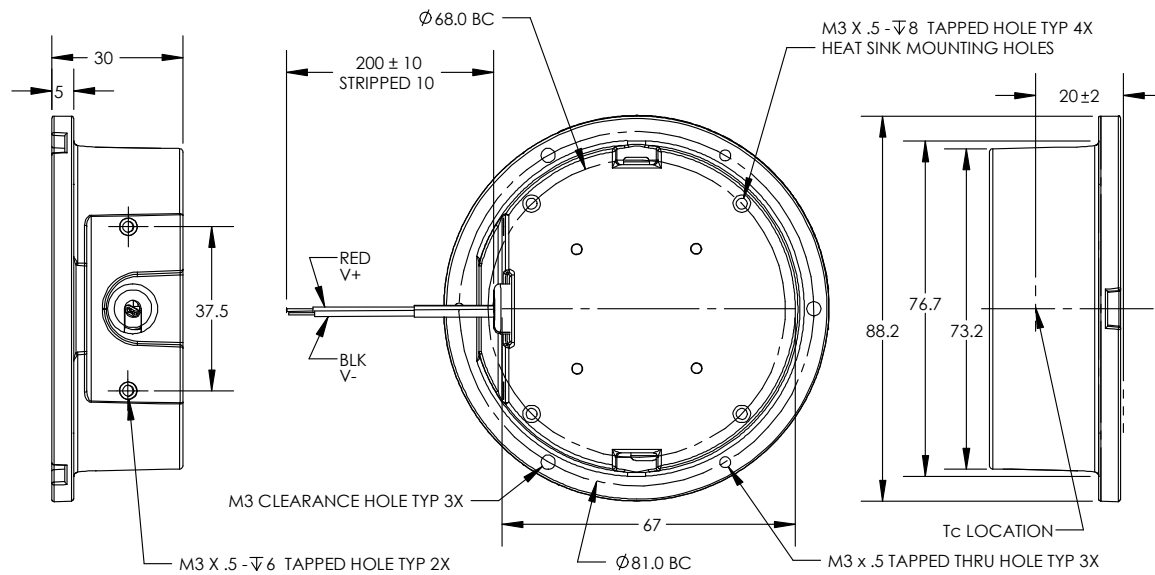

LMH2 Family Light Source (Dome Lens)

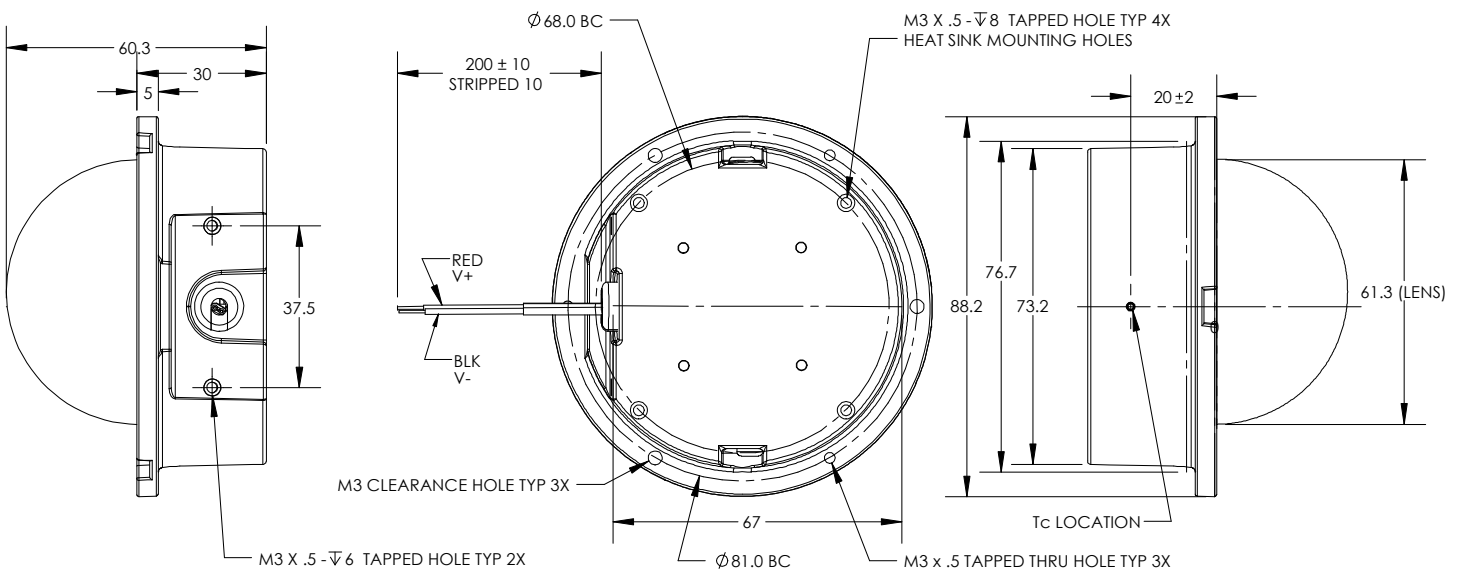

² Dimensions for the diagrams are in mm and are for reference only. For exact dimensions and tolerances, refer to the 3-D models (.STEP files) for the LMH2 light sources available by selecting the Documentation tab on the [LMH2 product page](#).