

## LMS-509 series

### Line Voltage Occupancy Sensor



## OVERVIEW

The LMS-509 series member of the TRANS family is a line voltage switching occupancy sensor designed for all-purposes energy efficient lighting control. This occupancy sensor employs an advanced High Frequency Doppler (HFD) sensing technology to provide superior sensing performance of minor motions, such as typing, writing, or reading. The HFD technology is operating with high frequency (4~12GHz) radio waves which is capable of detecting the occupant's presence and movements without requiring unobstructed line-of-sight like PIR sensors.

The Accu-Set digital potentiometer makes the sensor setting easier, faster and more accurate than the conventional analog potentiometer. 4 levels of sensitivity can be selected to provide optimum range via DIP switch setting. An exclusive Hybrid Switching technology makes LMS-509 series ideal to control the lighting with exceptionally high inrush current (HIC) while switching on, such as multiple LED or CFL lightings connected in parallel. The sensor comes with ambient light sensor (ALS) to inhibit switching on the light if the ambient light level is higher than the threshold set.

Like all sensors in the TRANS family, the LMS-509 series is also available in various mounting options. This provides a second-to-none design and installation flexibility.

## FEATURES

- High Frequency Doppler sensing technology
- 120/277 VAC line voltage operation
- Hybrid switching for controlling loads with HIC
- Accu-Set potentiometer for quick and easy setting
- 4 levels of HFD sensitivity setting programmable
- Ambient light sensor to inhibit unneeded lighting
- Available with a variety of mounting options

## APPLICATION

Light Control

Fan Control

The LMS-509 series occupancy sensor can be used to directly control the connected light, or other loads, by sensing the presence and movements of the occupant without requiring unobstructed line-of-sight. This makes the sensor suitable for applications such as an open office with partitions, a library reading area with cubicles, a restroom with stalls, inside a plastic wall box safety cover, or mounted inside of an enclosed lighting fixture.

NOTE: Do NOT place the sensor behind a metal plate or within an enclosure with high metallic wall.

# LMS-509 series

## Line Voltage Occupancy Sensor

### OPERATION

The LMS-509 series is a line voltage operating occupancy sensor with hybrid switching output to control the operation of connected load. The sensor will switch on the light when it detects the presence and movement of a moving object (human, or vehicle) within its coverage, and automatically shut off the light after the delay time elapses. Different delay times can be programmed by an Accu-Set digital potentiometer. An ambient light sensor is built-in to inhibit switching on the light when ambient light level is higher than the threshold set.

### DETECTION PATTERN

Mounting Height	10'	20'	
Coverage (sq. ft.)*	2,000	1,200	*Sensitivity 100%

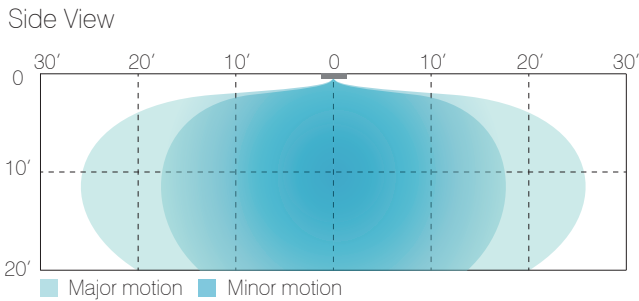

### Mounting Options

The LMS-509xX series can be mounted into the ceiling or integrated with an OEM lighting fixture in various options. The mounting options are available by combining a specific mounting bracket (if applicable) from the table below. The bracket will be shipped with the sensor when ordered with the respective code.

Code	Mounting Option	Mounting Bracket
F	Fixture Integrated	---
W	IP-66 Fixture Integrated	---
E	Fixture External	EMB-500
P	IP-66 Fixture External	PMB-500
S	Ceiling Surface	SMB-500
C	Junction Box	CMB-500
I	Fixture Internal	IMB-500

### Wiring Diagram

Various control modes may be achieved by different wiring connections. Basic wiring diagrams are included as below for reference. Consult with an IR-TEC team member if a more complex control is required.

#### A. Single sensor control

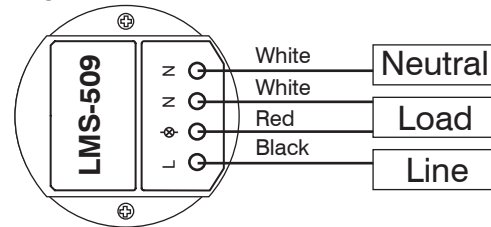

#### B. Multiple sensors control

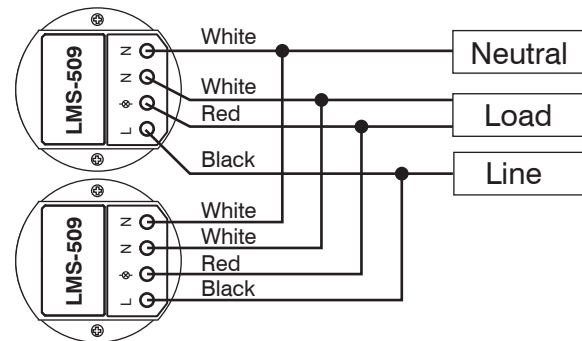

### SPECIFICATIONS

Power supply	120/277VAC
Maximum Load @ -40°F~131°F (-40°C~55°C)	Incandescent/Halogen – 800/1200W(VA)@120/277V
	Fluorescent Ballast/CFL – 800/1200W(VA)@120/277V
	Ballast Electronic (LED) – 540/1200VA@120/277V
Maximum Load @ 131°F~158°F (55°C~70°C)	Incandescent/Halogen – 500/750W(VA)@120/277V
	Fluorescent Ballast/CFL – 500/750W(VA)@120/277V
	Ballast Electronic (LED) – 500/750VA@120/277V
HFD sensitivity	25/50/75/100% selectable via DIP switch setting
Load switching	Zero-cross Hybrid-Switching
HIC protection	Max. 80A for 16.7msec.
Detection range	Up to 2,000 sq. ft. @ 10 ft
Mounting height	8 ~ 20 ft (2.4 ~ 6 m)
Ambient light level	7 level Accu-Set digital potentiometer
Delay time setting	T/1'/3'/5'/10'/20'/30', T=10 sec. for testing
Op. humidity	Max. 95% RH
Op. temperature	-40°F~158°F (-40°C~70°C)
Dimensions	Ø2.36"x H1.65" (Ø60 x H42mm)

## MOUNTING OPTIONS

### OVERVIEW

Each member of IR-TEC's TRANS sensor family is available with multiple mounting options with or without a mounting bracket. These mounting options allow the sensor to be integrated with lighting fixture or mounted on the ceiling in various ways. All applicable sensors can be supplied in specific mounting option as ordered with the respective code.

### Sensor Product Code



Mounting Option	Code	Bracket Model
Fixture Integrated	<b>F</b>	---
IP-66 Fixture Integrated	<b>W</b>	---
Fixture External	<b>E</b>	EMB-500
IP-66 Fixture External	<b>P</b>	PMB-500
Ceiling Surface	<b>S</b>	SMB-500
Junction Box	<b>C</b>	CMB-500
Ceiling Recess*	<b>R</b>	RMB-500
Fixture Internal	<b>I</b>	IMB-500

\*Line voltage sensors not applicable

### F/W-mount Sensor

#### Fixture Integrated

The sensors in **F** and **W**-mount are original form factor of TRANS family. Both options can be directly integrated with OEM lighting fixture through a 2" (51mm) diameter hole.





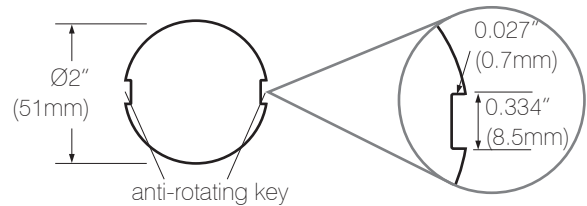





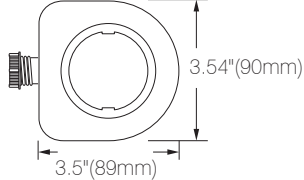

For IP-66 fixture integration, ensure to place the rubber gasket of **W**-mount sensor in between the fixture enclosure and sensor unit. Apply proper torque (0.3 lb-ft) to tighten the plastic screw nut while assemble the sensor.

### Assembly Hole

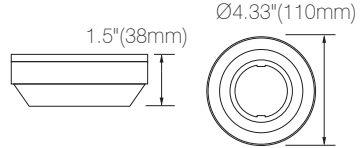

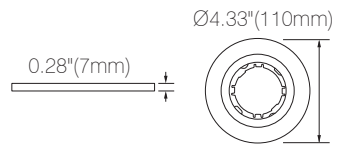

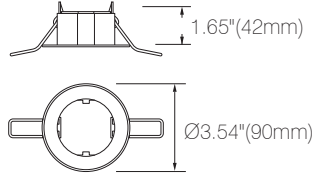
Occupancy sensor - PIR	Occupancy sensor - HFD	Daylight sensor

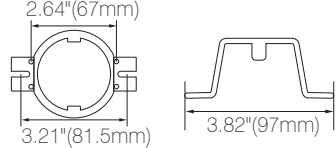
## Mounting Brackets

Bracket	Code	Description	Dimensions
 <b>EMB-500</b> 	<b>E</b>	<b>Fixture External</b> The <b>EMB-500</b> is a mounting bracket for mounting the sensor with indoor lighting fixture through a 1/2" knockout hole.	
 <b>PMB-500</b> 	<b>P</b>	<b>IP-66 Fixture External</b> The <b>PMB-500</b> is a mounting bracket for mounting the sensor with IP-66 lighting fixtures or outdoor pole mount through a 1/2" knockout hole.	
 <b>SMB-500</b> 	<b>S</b>	<b>Ceiling Surface</b> The <b>SMB-500</b> is a mounting bracket designed to mount the sensor on the surface of hard lid ceiling with or without junction box. Mounting on the surface of lighting fixture is also available.	
 <b>CMB-500</b> 	<b>C</b>	<b>Junction Box</b> The <b>CMB-500</b> is a ceiling mounting bracket designed to mount the sensor with an octagonal or square junction box.	
 <b>RMB-500</b>	<b>R</b>	<b>Ceiling Recess</b> The <b>RMB-500</b> is for recess mounting the sensor through a 2.8" (70mm) hole on the ceiling. An optional back cover ( <b>BC-500</b> ) is available for separate purchase if cable strain relief is required.	
 <b>IMB-500</b>	<b>I</b>	<b>Fixture Internal</b> The <b>IMB-500</b> is a mounting bracket exclusively designed for mounting the HFD sensor inside of an OEM lighting fixture.	

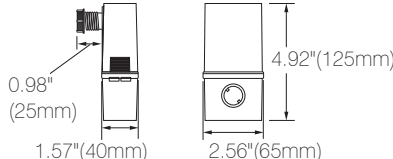
## Accessories

Accessory	Description	Dimensions
 <b>EMA-500</b>	<b>Extension Mounting Adaptor</b> The <b>EMA-500</b> is an extension mounting adaptor for lowering the position of E-mount sensor to avoid the coverage being blocked by the fixture body.	
 <b>EJ-30 EJ-50</b> 	<b>Extension Joint</b> The <b>EJ-30</b> and <b>EJ-50</b> are extension joints that can be used to horizontally extend the E/P mount TRANS sensor position for 30 and 50 mm. If longer extension is required, combine two joints for 60/80/100 mm. For outdoor use, order <b>EJ-30F</b> or <b>EJ-50F</b> .	