



MASTER LEDspot LV AR111

MAS LEDspotLV D 20-100W 840 AR111 24D

With its new perfect-fit design, the Master LEDspot LV AR111 now works with most of G53 luminaires as a true retrofit solution. The lamp creates a brilliant visual effect for retail and hospitality applications such as shops, showrooms and galleries. The high quality light brings out the true colors in merchandise and emphasizes its beauty. It also lasts long, with a strong lumen and color maintenance. The beautifully designed lamp offers a well-defined beam with a multitude of beam angles to suit various applications. Not only does it employ the Philips patented solution to ensure it is compatible with a broad selection of standard 12V halogen electronic transformers, it also delivers high beam intensity which equivalent to halogen AR111 spots of 50W, 75W or 100W.

Product data

General Information		Color Rendering Index (Nom)	
Cap-Base	G53 [G53]		80
Nominal Lifetime (Nom)	25000 h	LLMF At End Of Nominal Lifetime (Nom)	70 %
Switching Cycle	50000X	Operating and Electrical	
Technical Type	20-100W	Power (Rated) (Nom)	20 W
Light Technical		Lamp Current (Nom)	2400 mA
Color Code	840 [CCT of 4000K]	Wattage Equivalent	100 W
Beam Angle (Nom)	24 °	Warm Up Time to 60% Light (Nom)	0.5 s
Luminous Flux (Nom)	1400 lm	Power Factor (Nom)	0.7
Luminous Flux (Rated) (Nom)	1400 lm	Voltage (Nom)	12 V
Luminous Intensity (Nom)	6100 cd	Controls and Dimming	
Color Designation	Cool White (CW)	Dimmable	Yes
Rated Beam Angle	24 °	Approval and Application	
Correlated Color Temperature (Nom)	4000 K	Suitable For Accent Lighting	Yes
Color Consistency	<6		

MASTER LEDspot LV AR111

Energy Efficiency Label (EEL)	A
Product Data	
Full product code	871869651739000
Order product name	MAS LEDspotLV D 20-100W 840 AR111 24D
EAN/UPC - Product	8718696517390
Order code	929001171008

Numerator - Quantity Per Pack	1
Numerator - Packs per outer box	6
Material Nr. (12NC)	929001171008
Net Weight (Piece)	0.360 kg

Dimensional drawing

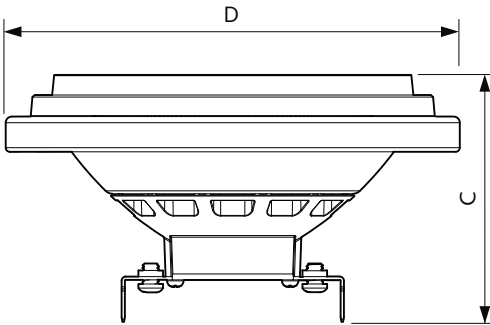

MAS LEDspot LV D 20-100W 840 AR111 24D

Product	D	C
MAS LEDspotLV D 20-100W 840 AR111 24D	111 mm	62 mm

Photometric data

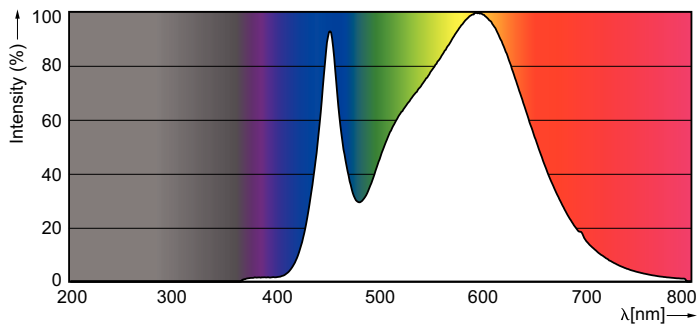
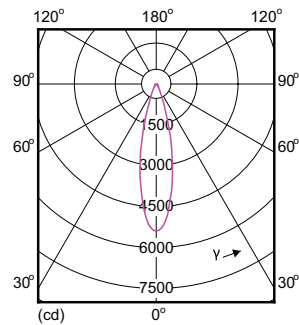
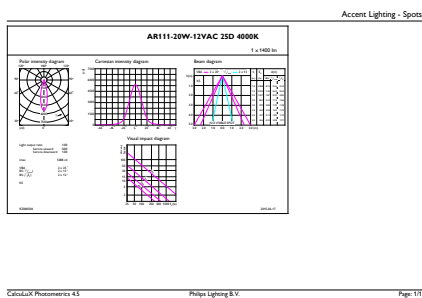

20-100W AR111 /840

MASTER LEDspot LV AR111

Lifetime

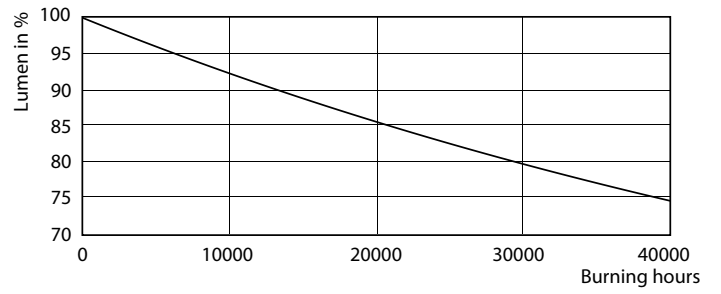
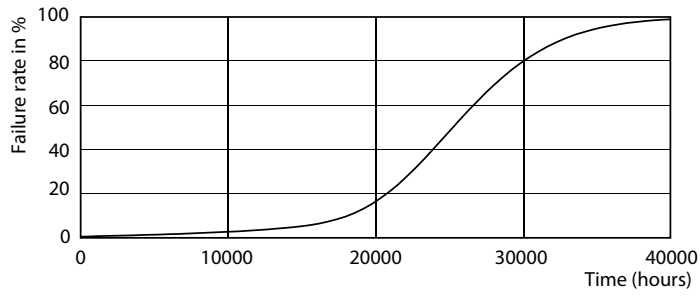

MASTER LEDspotLV AR111 100W G53 40D

MASTER LEDspotLV AR111 100W G53 40D

