

OVERVIEW

The **MP20** power/relay pack and **MSP20** secondary relay pack work with low voltage occupancy sensors to switch lighting loads on and off. The **MP20** also transforms 120, 240, and 277 VAC single phase power to Class 2 15 VDC to power remote sensors. Although plenum rated, the elongated mounting nipple allows for these packs to be mounted either directly through a 1/2 inch knockout in a junction box, or to be located inside an adjacent box for specific local code requirements. Up to 14 sensors may be connected to one **MP20**. Multi-circuit control can be handled by multiple **MP20** or **MSP20** packs. **MP20**s can be wired continuously hot (line side), or on the switch leg (load side) without nuisance delays upon turn on.

FEATURES

- Powers Low Voltage Sensors (MP20)
- Switches Line Voltage Loads
- Plenum Rated

SPECIFICATIONS

Size:	(not including chase nipple) 3.00" H x 2.25" W x 1.88" D (7.62 cm x 5.72 cm x 4.78 cm)
Weight:	6 oz
Mounting:	1/2" knockout
Color:	Black
Operating Voltage:	120, 240, 277 VAC (single phase)
Relay Current Reqs:	40 mA
Switching Load:	20 Amps
Output Voltage/Current:	15 VDC, 150 mA at 120 or 277 VAC (MP20)
Motor Load:	1 HP
ROHS compliant	

Warranty

Five-year limited warranty. Complete warranty terms located at:
www.acuitybrands.com/CustomerResources/Terms_and_conditions.aspx

Note: Actual performance may differ as a result of end-user environment and application.

Specifications subject to change without notice.



Sensor Switch™

MP20

MSP20

Power Pack/ Secondary Pack



ORDERING INFORMATION



MP20		Example: MP20 LT
Series		Temperature/Humidity
MP20	Power/ Relay Pack	[blank] Standard
MSP20	Secondary Relay Pack	LT Low Temp

WIRING (DO NOT WIRE HOT)

POWERING CAPACITY

An **MP20** power pack's transformer can supply up to 150 mA of power. Each relay requires 40 mA during the on state. Low voltage remote sensors typically require 3 mA when detecting occupants, and 0.15 mA when in standby. Therefore, each transformer can handle up to 3 relays (including its own relay). For example, one **MP20** can power its relay (40 mA) and 110 mA of external devices. Because of the ultra low current design of Sensor Switch sensors, up to 14 sensors can be connected to a single power pack. If multiple power packs are used together, an additional 110 mA is available.

	Sensors	Sensors w/ -R (aux. relay) option
1 MP20	14	8
1 MP20 w/MSP20	7	6
2 MP20	28	16

Note 1: Only three relays may be controlled with one power pack. If controlling more than three circuits is required, multiple power packs must be used.

Note 2: Only one sensor with auxiliary relay (-R option) is required in most cases. See datasheets on low voltage sensors.

LOW VOLTAGE OPERATION AND TEST

The pack's low voltage wires are color coded: Red (15 VDC), Black (Common), and White (Occupancy Signal). With no sensors connected, touch the Red wire to the White wire. The lights should turn on. Remove the connection and the lights should turn off. With the sensors connected, the Red and Black wires provide DC power to the remote sensors, and when there is occupancy detected, the White wire produces a 15 VDC signal from the sensor to the power pack initiating the lights to on. Upon initial power up, the sensors automatically send an on signal until the sensors have stabilized and their time delays have expired.

TYPICAL WIRING

The Power Pack must be connected to a single phase Hot and Neutral System. For 120 VAC, connect the Black wire to Hot, White wire to Neutral, and Cap off the Orange wire. For 240-277 VAC, connect the Orange to Hot, White to Neutral, and Cap off the Black wire. **Never connect both the Black and Orange wires!** Low Voltage wire can be 18 to 22 AWG; shielding is not necessary.

One Sensor & One Power/Relay Pack

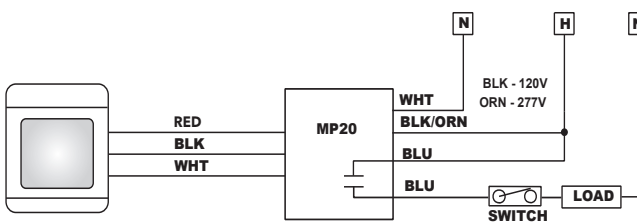

Multiple Sensors & One Power/Relay Pack

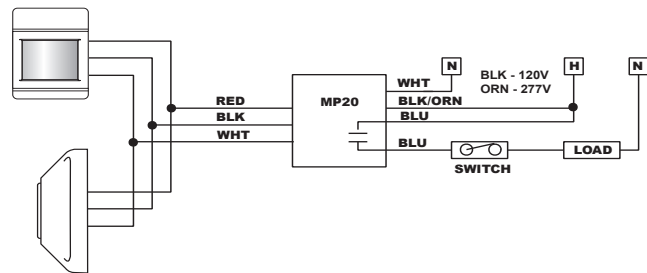

Multiple Power Packs & Secondary Packs

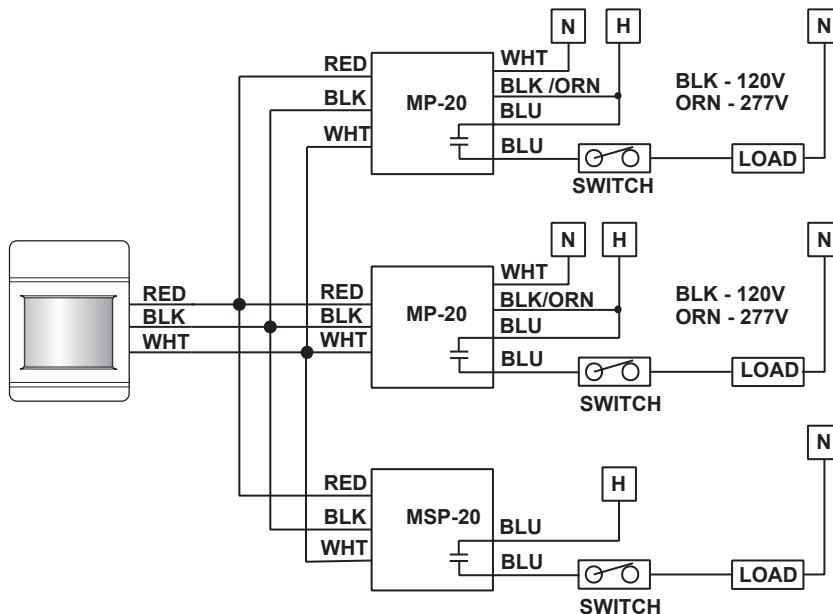

M(S)P20 - T053