

## Product Characteristics

- Efficiency : Up to 95%
- Dim method: 0-10V/PWM/RX, Dim-to-off.
- Functional: External Adj. power
- IP Rating : IP54
- Surge : 6+6KV
- Warranty : 5 years

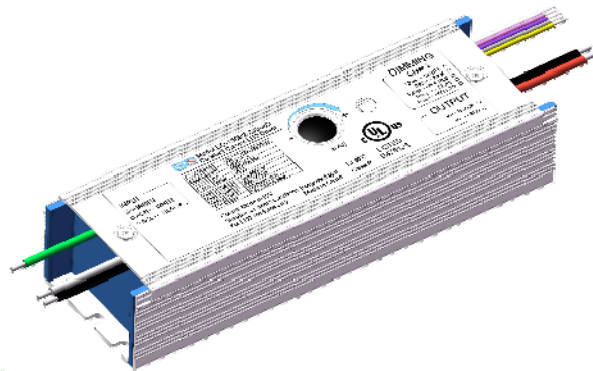

## Product Description

This series is designed for the constant current LED drive with long/non-isolated /bipolar/flicker-free, (Dimming and auxiliary functions are isolated)

This series is mainly designed and developed for: Liner High-bay/Shoebox/Wall pack/Floodlight and other outdoor products. It's a series of products with high efficiency, high reliability, high stability and high cost performance.

## ModelList

Model	Pout max.	Vac <V>	Output Range Vdc	Recommended Output Vdc	Iout <mA>	Default <mA>	Eff. %
BQ-150B2-260-D	150	100-277	180-260	200-250	500-750	600	95%

“Z” Suffix“-Z” -D

Function description 0-10V+External Adj. line

1:Explain for Model: [BQ] -Logo, [XXX] -Pout Max [B2] -Series, [260] -Vout-180-260V, [Z] -as above table

2.External Adj. line(Preg+/Preg-): means that the driver can lead out 2 lines separately for external connect board to adjust power and CCT;

**\* Warning\***

When using the adjustable output current function, the actual output voltage x output current of the light board cannot exceed the maximum output power of the drive;

## Input Characteristics

Parameters	Min.	Typ.	Max.	Unit	Test Conditions/Remark
Rated Input Voltage Range	100	/	277	<b>Vac</b>	120-277Vac for US only
Input voltage range	90	/	305	<b>Vac</b>	Reduction used when in 120Vac -Reference reduction curve
Input frequency	47	50/60	63	<b>Hz</b>	/
Input current	/	/	1450	<b>mA</b>	@120Vac
Inrush Current	/	/	120	<b>A</b>	@100% load at 277Vac input cold start
PF	0.95	0.97	/	<b>N/A</b>	@230Vac100% Full load
	0.9	/	/	<b>N/A</b>	@120-277Vac70% Full load
THD	/	10	12	<b>%</b>	@230Vac100% Full load
	/	/	20	<b>%</b>	@120-277Vac70% Full load
Flicker	/	/	5	<b>%</b>	@120-277Vac
Turn-on Delay Time	/	/	750	<b>mS</b>	@120Vac
No Load Power	/	/	5	<b>W</b>	@120-277Vac
Short circuit power	/	/	10	<b>W</b>	@120-277Vac (Hiccup mode)

## Output Characteristics

Parameters	Min.	Typ.	Max.	Unit	Test Conditions/Remark
Rated Vout	180	/	260	<b>Vdc</b>	/
Rate output current(adjust)	500	/	750	<b>mA</b>	±5%   Rated Vout * RatedIout ≤Pout
Rated Pout	/	/	150	<b>W</b>	@100% load at 120-277Vac
No-Load Voltage	/	/	310	<b>Vdc</b>	@120-277Vac
Efficiency@120Vac	91	93	/	<b>%</b>	@ Full load Output: 260v/0.38A
Efficiency@230Vac	93	95	/	<b>%</b>	@ Full load Output: 260v/0.38A
Efficiency@277Vac	93	95	/	<b>%</b>	@ Full load Output: 260v/0.38A
Line Regulation	-5%	/	+5%	<b>%</b>	@ Full load
Load Regulation	-5%	/	+5%	<b>%</b>	
(PK-AV) Ripple Current	/	-5%	15%	<b>%</b>	@ Full load

## Dimming Characteristics

Function	Parameters		Min.	Typ.	Max.	Unit	Remark
0-10V Dimming (Optional) Class2	Applied maximum voltage		0	/	12	V	DIM+ output 100uA current
	Dimming output current range		0	/	100	%	Strong dimmer compatibility
	Dimming voltage		0	/	10	V	
	Dimming current		90	100	110	uA	
Dimmer	Brand	Leviton	Lutron				Applicable voltage 120-277VAC 50/60HZ
<General>	Model	IP710-LF Z	DVSTV	NTSTV			
PWM Dimming (Optional)	PWM high level		9.8	/	10.2	V	DIM+output 100uA current
	PWMf requency range		1	/	2	KHz	
	PWM Duty Cycle		0	/	100	%	
Rx.Dimming (Optional)	External Rx.value		0	/	100	Kohm	DIM+output 100uA current
	Rx.Dimming Range		0	/	100	%	
Turn-off Voltage	0-10V	Turn-off voltage	0.6	0.8	1.0	V	Dimming line short circuit turn off light
		Turn-on voltage	0.7	0.95	1.2	V	
	1-10V		/	/	/		Dimming line short circuit does not turn off light
Cautions	When the dimming line is not in use,please take insulation measures for the dimming line,pay special attention to high voltage protection,and never connect it tohigh voltage;						

## Protection Functions

Function	Parameters	Min.	Typ.	Max.	Unit	Remark
OTP	Current reduction mode	90	92	100	°C	When the over temperature is released,the current automatically resumes.
SCP	Long-term short circuit without damage-Hiccup mode					Automatic recovery after short circuit is removed
OCP	The output voltage will be limited to the specified range					Automatic recovery mode
Others						

## Environmental Requirements

Parameters	Min.	Typical	Max.	Unit	Remark
Operating temperature	-40	/	90	°C	Tc
StorageTemp./Humidity	-40	/	90	°C	RH:5%~95%
Tc	/	/	90	°C	case Temp.
50000H/ @Tc85°C	/	85	/	°C	Reference life curve (full load)
MTBF@ 25°C	/	200000	/	H	80%full load MIL-HDBK-217F

## Safety and EMI

Certification	Safety	Country	Certification Standards	Remark
<input type="checkbox"/>	CCC	China	GB19510.1;GB19510.14 GB17625.1;GB/T17743	
<input checked="" type="checkbox"/>	UL/Cul	USA/Canada	UL8750	
<input checked="" type="checkbox"/>	CE-LVD	Europe	EN61347-2-13; EN61347-1 EN62384	
<input checked="" type="checkbox"/>	CB	Member states	IEC61347-2-13 IEC61347-1	
<input checked="" type="checkbox"/>	ENEC	Europe	EN62384	
<input type="checkbox"/>	SAA	Australia	AS/NZS61347.1+AS/NZS61347.2.13	

EMI/EMS	Area	Standard	Test Conditions/Remark
FCC	USA	Part 15, ANSI C63.4	Class B
EMC	Europe	EN/IEC55015; EN61547;EN/IEC61000-3-2 EN61000-3-3	Class C
Surge	Europe	IEC/EN61000-4-5	DM L-N:6KV CM L-N&Gnd:6KV
Ring wave	USA	IEC/EN 61000-4-12; ANSI/C82.77-5	2.5KV
ESD	Europe	EN 61000-4-2	8 KV air discharge 4 KV contact discharge

Remark: The LED Driver itself complies with EMC standard. However, the LED Driver's EMC should be re-checked with lamp when integrated into lighting systems.

Insulation requirements	UL	CE	CCC	Unit	Remark
Input-Case	2U+1000	2U+1000	/	Vac	Basic insulation
Input-Dim	2U+1000	3000	/	Vac	Reinforced insulation
Dim-Case	500	500	/	Vac	Basic insulation
Insulation Resistance	> 10	> 10	/	MΩ	Input vs dimming@500Vdc/25°C
Ground Resistance	< 0.1	< 0.1	/	Ω	GND vs Case,25A/1min
Leakage Current	≤0.75	≤0.75	/	mA	@277Vac
Warning	When you test Hi-pot, Please short circuit between L/N, short circuit between positive/negative output line, short circuit between positive/negative dimming and auxiliary power supply.				

### Performance Curves

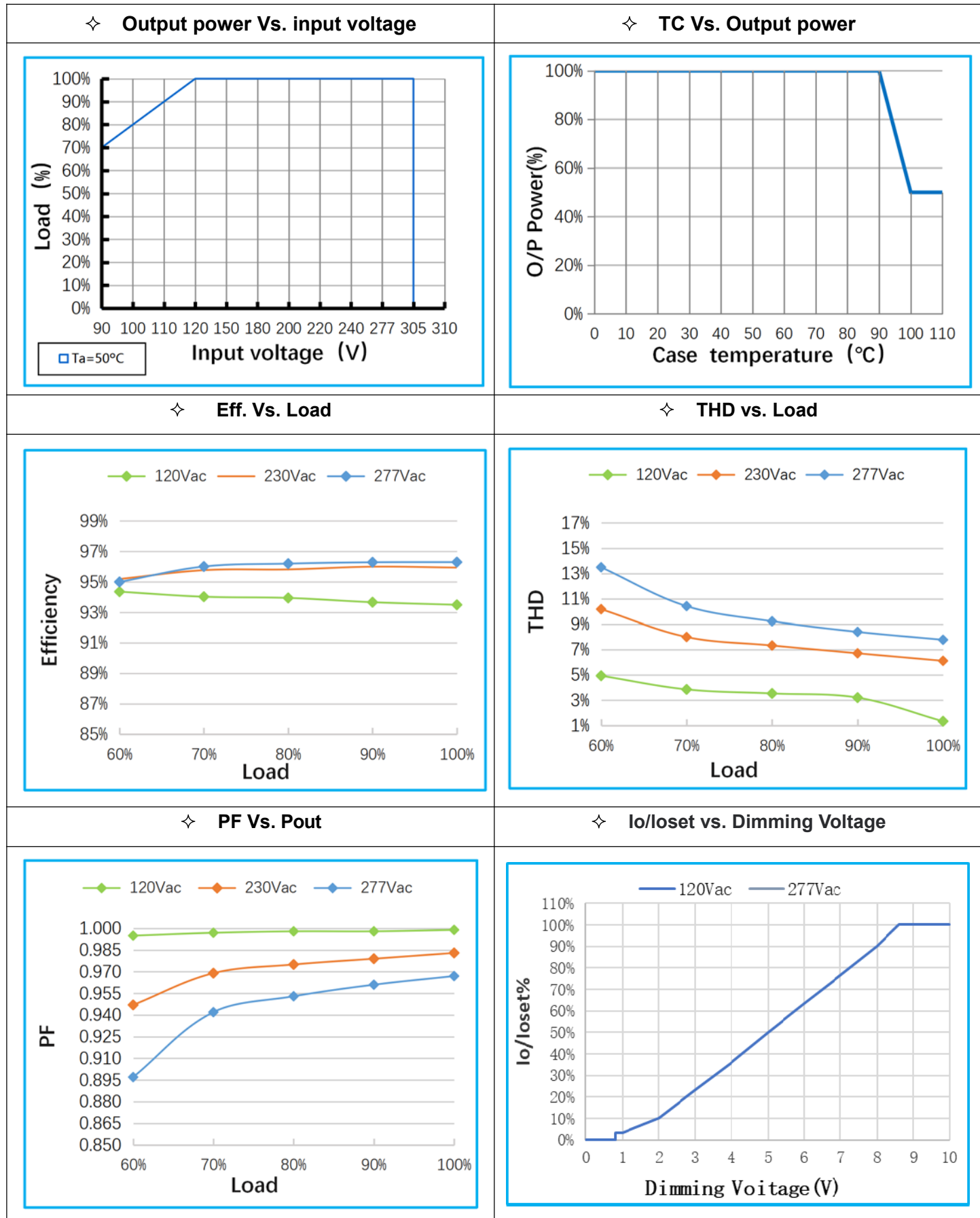

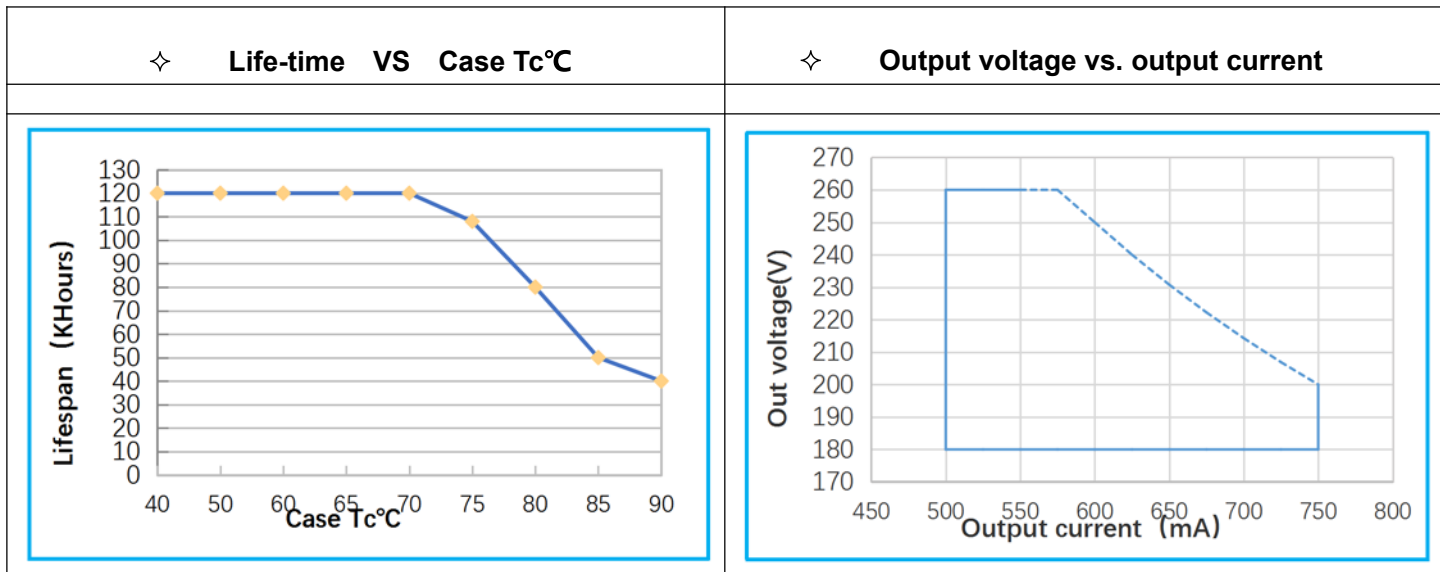

### Wiring Diagram

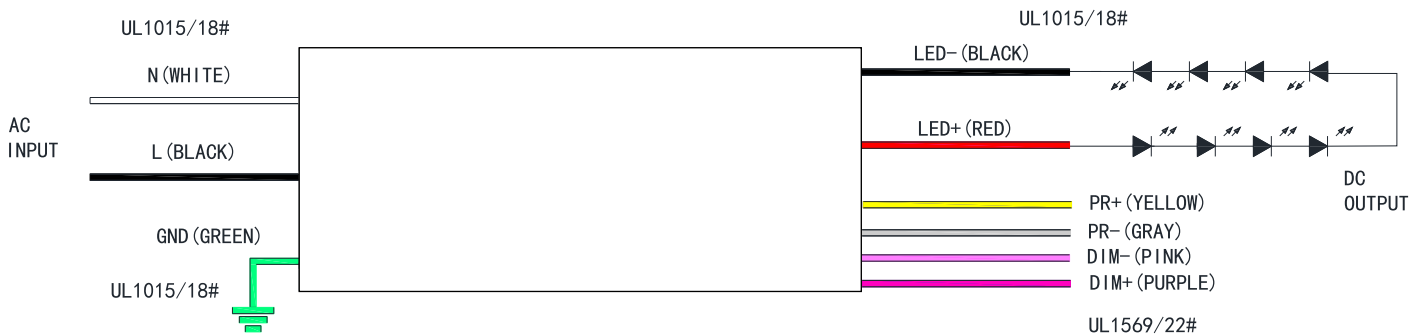

**Warning:** During the application operation, the isolated 0-10V dimming line/Preg+/Preg- should avoid contact with high voltage to prevent voltage backflow and damage to the power supply;

### Structure Size

Material of case	Size (mm)						Tc position		Tolerance	Weight	Tolerance	Process
	A	B	C	L	W	H	X	Y				
Aluminum	154	141	30	160	52.5	33.5	111.5	16	±2mm	0.5kg	±50g	glue

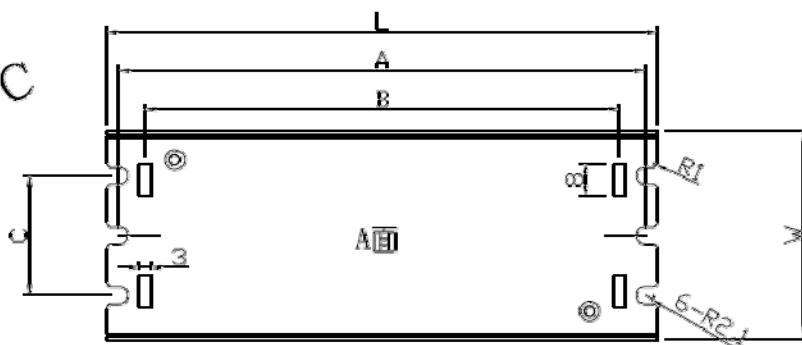
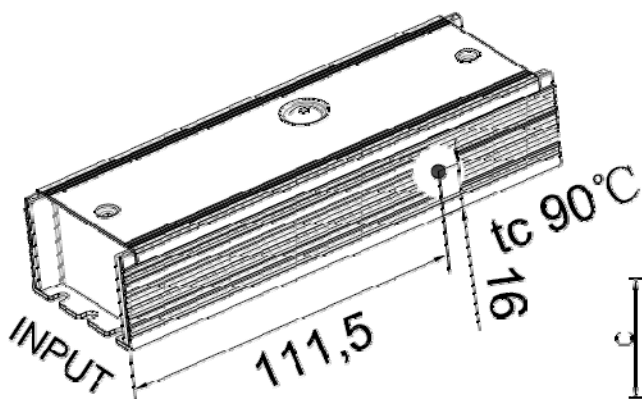

Item		Color	AWG	AWG	Exit method
Input line	ACL	Black	UL1015	AWG18 600V/105°C	Open skin and tin 10mm
	ACN	White			
	GND	Green			
Output line	LED +	Red	UL1015	AWG18 600V/105°C	Open skin and tin 10mm
	LED -	Black			
Dim-line	Dim +	Purple	UL1569	AWG22 300V 105°C	Open skin and tin 10mm
	Dim -	Pink			
Adj. line	Preg+	Yellow			Open skin and tin 10mm
	Preg-	Gray			



#### Considerations design for Non-isolated driver light board

- 1) It is recommended to arrange the lamp beads in parallel first and then in series;
- 2) The aluminum substrate withstands voltage >3KV;
- 3) The recommended distance from all traces to the copper foil on the edge of the board is >4.7mm;
- 4) The creepage distance between LED+ and LED- on the aluminum substrate is >2.5mm; Non-isolated power supply use light board design precautions;
- 5) No excess heat dissipation copper foil is covered on the aluminum substrate;