

QUICKTRONIC® PROStart® T5 Universal Voltage Systems

Type CC

Programmed Rapid Start
Normal Ballast Factor



High Efficiency Series

QHE T5 PSN

Lamp / Ballast Guide

28W T5 – PENTRON® lamps
1 or 2 lamp QHE2x28T5/UNV PSN

Primary Lamp Type:
FP28

Also operates:
FP14, FP21, FP35

Two lamp fixed output model can be
wired for one lamp operation.

Key System Features

- High Efficiency Systems over 90% efficient
- Universal voltage (120-277V)
- Low-profile (0.87" High)
- 1.0 Ballast factor (see table)
- QUICKSENSE® ballast technology (end-of-lamp-life sensing)
- PROStart programmed rapid start
- Min. starting temperature
 - -20°F (-29°C)
- Operates at >42 kHz to reduce potential interference with infrared control systems
- Meet the most demanding utility rebate standards
- UL Type CC rated
- RoHS compliant
- Lead-free solder, printed circuit board and manufacturing process



Application Information

SYLVANIA QUICKTRONIC PS ballasts are ideally suited for:

- Commercial
- Retail
- Hospitality
- Institutional
- New construction
- Direct lighting
- Indirect lighting
- Surface mount
- Cove lighting

SYLVANIA QUICKTRONIC High Efficiency (QHE) PROStart T5 Universal Voltage electronic ballasts operate PENTRON T5 lamps saving >2 watts as compared to standard T5 ballasts.

QUICKTRONIC PROStart T5 ballasts feature programmed rapid start lamp starting and operation which provides optimum conditions to deliver up to 100,000 switching cycles for use on occupancy sensors and building control systems.

QUICKTRONIC PROStart T5 ballasts are RoHS compliant and feature lead-free solder, printed circuit boards and manufacturing process.

Setting the standard for quality, QUICKTRONIC PROStart T5 systems are covered by the QUICK 60+® warranty, the first and most comprehensive system warranty in the industry.

System Information

SYLVANIA QUICKTRONIC PS T5 High Efficiency (QHE) System advantages:

- Operate from 120V through 277V
 - Eliminates “wrong voltage” errors
 - Reduces inventory by 50%
- Utilizes Programmed Rapid Start operation for:
 - Highest System Efficacy
 - Longer Life
 - Over 100,000 switching cycles for occupancy sensor and building control systems applications

QUICKSENSE ballast technology helps to protect against overheated bases and sockets, as well as cracking of the glass wall, and uses dynamic end-of-lamp-life sensing to avoid false shutdowns caused by some static sensing methods. QUICKSENSE ballast technology will auto reset when the end-of-life lamps are replaced with new ones.



System Type (2-lamp)	Input Power (W)	Initial System Lumens	Initial System Efficacy (LPW)	Mean System Lumens	Relative Mean Light Output	Energy Savings (%)
2-F40T12 ES Mag. Ballast	86	5795	67	4925	100%	Baseline
2-F032/700 QTP2x32T8/UNV ISN-SC	59	4930	84	4435	90%	31%
2-FP28T5/800 QTP2x28T5/UNV PSN	65	5800	89	5395	111%	24%
2-FP28T5/800 QHE2x28T5/UNV PSN	63	5800	92	5395	111%	27%

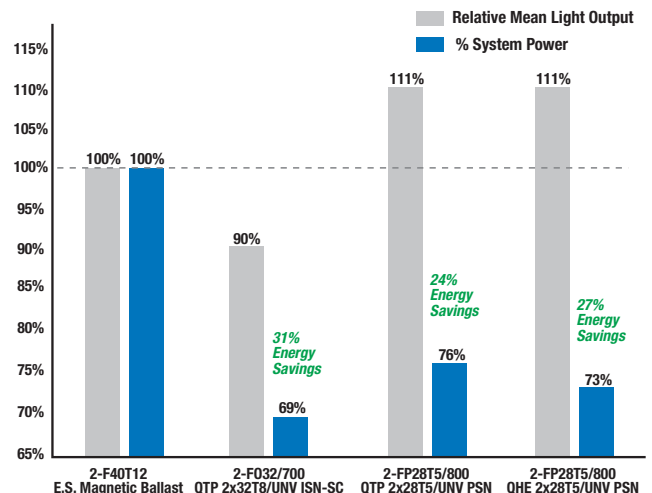

SPECIFICATION DATA

Catalog #	Date	Type
Project	Prepared by	
Comments		

Normal Ballast Factor

T5 PROStart®

High Efficiency

Performance Guide

Data based upon SYLVANIA PENTRON® lamps shown. QUICKTRONIC® ballasts are also compatible with other lamp manufacturers equivalent lamp types that meet ANSI specifications.

High Efficiency Type CC & Universal Voltage (120-277V)



Item Number	OSRAM SYLVANIA Description	Input Current (AMPS)	Lamp ¹ Type	Rated ¹ Lumens (lm)	No. of Lamps	Ballast ¹ Factor (BF)	System ¹ Lumens	Mean ¹ Lumens	Input ¹ Power (W)		System ³ Efficacy (lm/W)	BEF ²	
									120V	277V			
51473 Ⓞ (51472) Ⓞ	QHE2x28T5/UNV PSN 20-pack (without leads) 10-pack (with leads)	0.55/0.23	FP28T5	2900	2	1.00	5800	5395	63	62	94	1.61	
		0.68/0.29	FP35T5	3650	2	0.99	7225	6720	80	78	93	1.27	
		0.39/0.18	FP21T5	2100	2	1.01	4240	3945	47	46	92	2.20	
		0.27/0.13	FP14T5	1350	2	1.03	2780	2585	32	32	87	3.22	
			0.27/0.12	FP28T5	2900	1	1.00	2900	2695	33	32	91	3.13
			0.34/0.15	FP35T5	3650	1	1.02	3725	3460	41	40	93	2.55
			0.21/0.10	FP21T5	2100	1	1.04	2185	2030	25	24	91	4.33
			0.15/0.07	FP14T5	1350	1	1.03	1390	1295	17	17	82	6.06

¹ At 35°C lamp ambient temperature.
² Ballast Efficiency Factor (BEF) shown = (Ballast Factor x 100) divided by Input Power (Note: calculation based on lowest wattage value).
³ System Efficacy calculation based on lowest input power value.
 Ⓞ Preliminary specifications. Please contact OSRAM SYLVANIA for additional information.

QHE T5 PSN

Specifications⁴

- Starting Method: Programmed Rapid Start
- Ballast Factor: 1.00 (see table)
- Circuit Type: Series
- Lamp Frequency: >42 kHz
- Lamp CCF: Less than 1.6
- Starting Temp: -20°F (-29°C)⁵
- Input Frequency: 50/60 Hz
- Low THD: <10%
- Power Factor: >98%
- Voltage Range: ±10% of 120-277V rated line (108-305V)

UL Type CC rated
 UL Listed Class P, Type 1, Outdoor
 CSA Certified
 70°C Max Case Temperature
 FCC 47CFR Part 18 Non-Consumer
 Class A Sound Rating
 ANSI C62.41 Cat. A Transient Protection
 QUICKSENSE Dynamic End-of-Lamp-Life Sensing
 Remote Mounting (Max. wire length from ballast case to lampholder): up to 18 feet. Remote red leads up to 18 feet. Keep blue leads <10 feet.
 RoHS Compliant⁶

⁴ Data based on PENTRON 28W lamp types for primary ballast application.
⁵ Operation below 50°F (10°C) may affect light output or lamp operation – see “Low Temp. Starting” definition.
⁶ Complies with European Union Restriction of Hazardous Substances Directive.

System Life / Warranty

QUICKTRONIC products are covered by the QUICK 60+® warranty, a comprehensive lamp and ballast system warranty. For additional details, refer to the QUICK 60+ warranty bulletin.

OSRAM SYLVANIA
National Customer Service and Sales Center
 1-800-LIGHTBULB
 (1-800-544-4828)
www.sylvania.com

Specifications subject to change without notice.

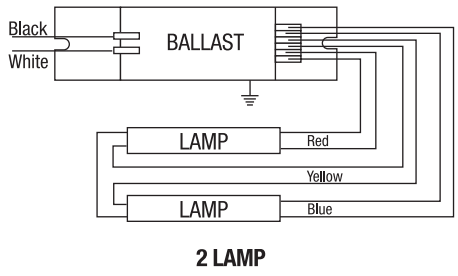
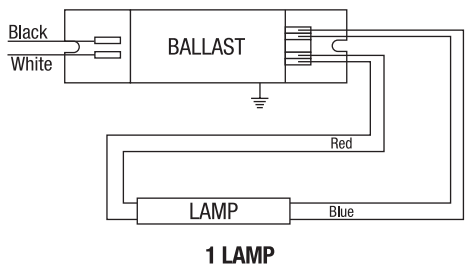

Dimensions:
 Model QHE2x28T5/UNV PSN enclosure size:
 Overall: 14.17" L x 1.18" W x 0.87" H (360mm L x 30mm W x 22mm H)
 Mounting: 13.74" (349mm)

Wiring:
 51473: Push-in connectors
 51472: Push-in connectors with leads
 Use 18AWG solid copper wire only

Product Weight:
 51473: 0.68 lb (0.30kg) each (approx.)
 51472: 0.88 lb (0.40kg) each (approx.)

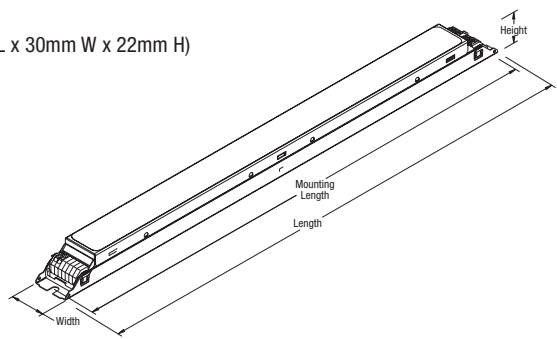

Item Number	51473 QHE 2 x 28T5 / UNV PSN	Starting/Ballast Factor
QUICKTRONIC High Efficiency		Line Voltage (120-277V)
Number of Lamps (2)		Primary Lamp Wattage