

| LTR | REVISION | DATE | APPD |
|-----|----------|----------|------|
| - | RELEASED | 12-06-18 | |

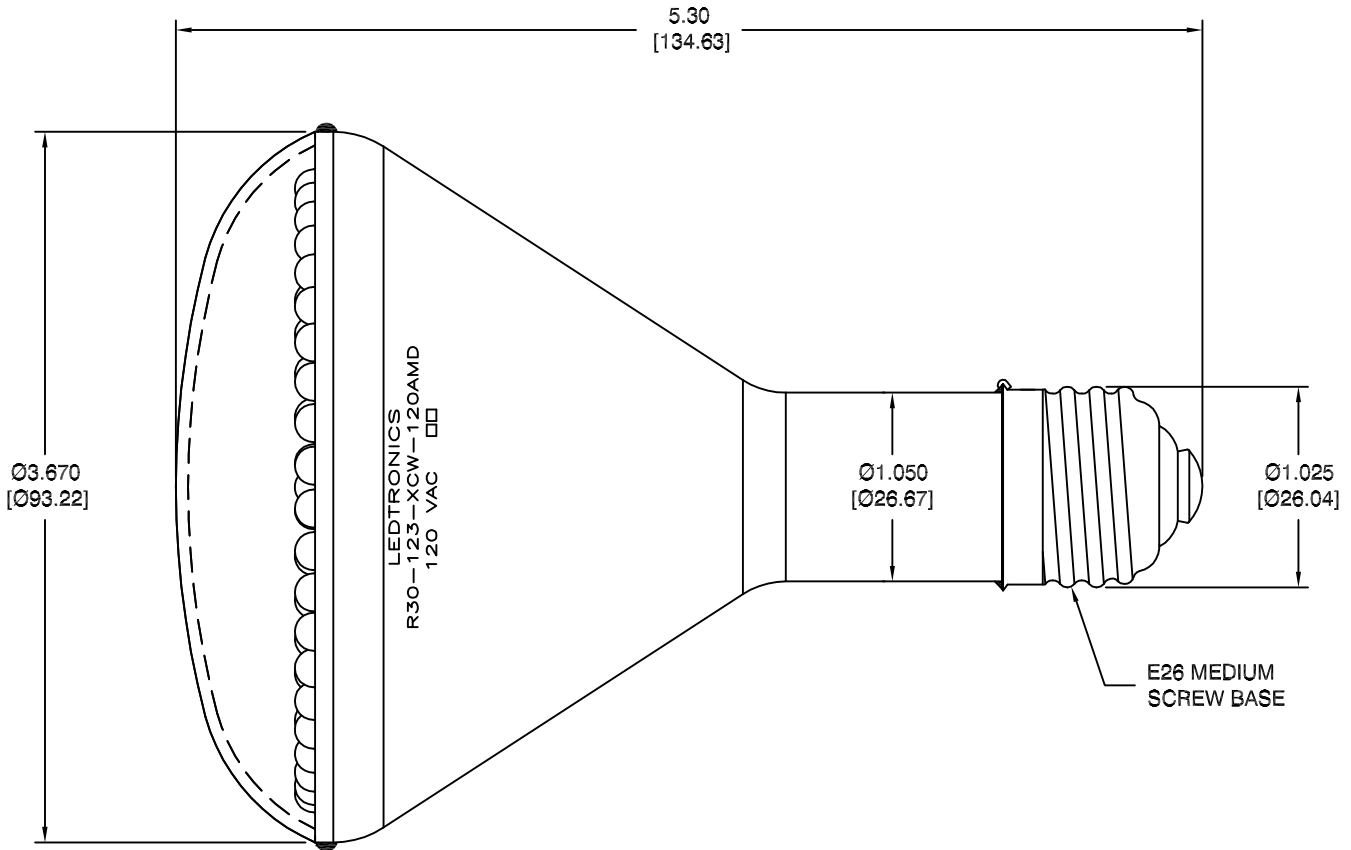

NOTES:

1. ALL DIMENSIONS ARE IN INCHES [MILLIMETERS].
2. PART IS DIMMABLE.
3. LENS MATERIAL / COLOR: UV STABILIZED POLYCARBONATE, UL94-V0 / CLEAR
4. SLEEVE MATERIAL / COLOR: UV STABILIZED POLYCARBONATE, UL94-V0 / SILVER
5. BASE MATERIAL: BRASS, NICKEL PLATED BRASS

| REVISION NOTIFICATION | |
|--------------------------|---|
| <input type="checkbox"/> | DLC |
| <input type="checkbox"/> | UL/ETL |
| <input type="checkbox"/> | MADE IN USA |
| <input type="checkbox"/> | CUSTOMER _____ |
| <input type="checkbox"/> | OTHER |
| REDLINE CHECKLIST | |
| <input type="checkbox"/> | REDLINE(YES) |
| <input type="checkbox"/> | DATE: _____ |
| <input type="checkbox"/> | INITIATED BY: _____ |
| <input type="checkbox"/> | ECR REQUIRED YES <input type="checkbox"/> NO <input type="checkbox"/> |
| <input type="checkbox"/> | WORK ORDER# _____ |

ELECTRICAL-OPTICAL CHARACTERISTICS (Ta = 25°C)

| R30-123-XCW-120AMD | COOL WHITE | 120Vac | 4.5 W | 0.028-0.045 A | 400cd | 164 lm | 8000K | 37° |
|---------------------|---------------|------------------|-----------|---------------|-----------------|--------------|-----------------|---|
| LEDTRONICS PART NO. | COLOR EMITTED | INPUT VOLTAGE, V | POWER (W) | CURRENT (A) | MAXIMUM CANDELA | TOTAL LUMENS | COLOR TEMP. (K) | VIEWING ANGLE (FULL BEAM WIDTH @ 50% INTENSITY) |

| | | | | | | | | | | | |
|---|---|--|--|----------|--------|----------|----------------|--------|----------|----------|----------|
| <p>LEDTRONICS,™ INC. 23105 KASHIWA COURT TORRANCE, CA 90505</p> | <p>-PROPRIETARY- This document contains Proprietary Information of LEDTRONICS, INC. It may not be copied, used or disclosed for any purpose without the prior express written consent of LEDTRONICS, INC.</p> | | <p>TITLE R30-123-XCW-120AMD</p> | | | | | | | | |
| | <p>.XXX ± .010 TOLERANCE PER ANSI-Y14.5 .XX ± .025 (UNLESS OTHERWISE STATED) ANGLES ± 0°,30' FRACT. ± 1/32</p> | | DWG NO | SCALE | SHEET | DATE | | | | | |
| | | | SDBD1298-CUST | 1:1 | 1 OF 1 | 12-06-18 | CODE IDENT NO. | DWG BY | CHK BY | QA | MFG |
| | | | 8Z410 | 12-06-18 | | EE | LD | UF | 12-13-18 | 12-13-18 | 12-13-18 |