

LTR	REVISION	DATE	APPD
C	080117-GP01: ADDED WEIGHT TO NOTES	08-01-17	GP

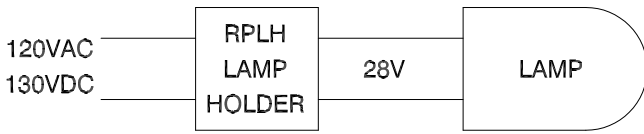

LAMP HOLDER SERIES - RPLH16-02

LED LAMP SERIES - RPLB-020X

LENS - RPLL16-XXF

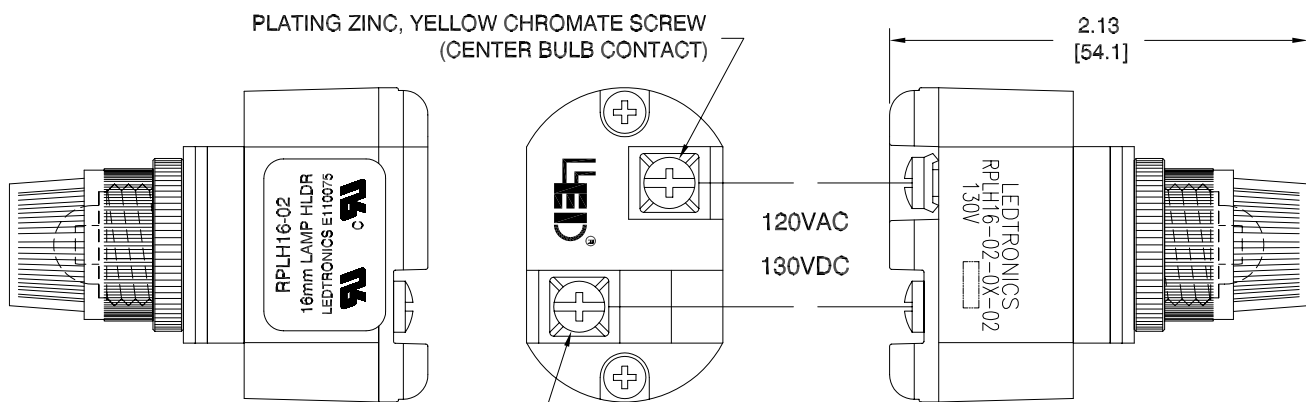
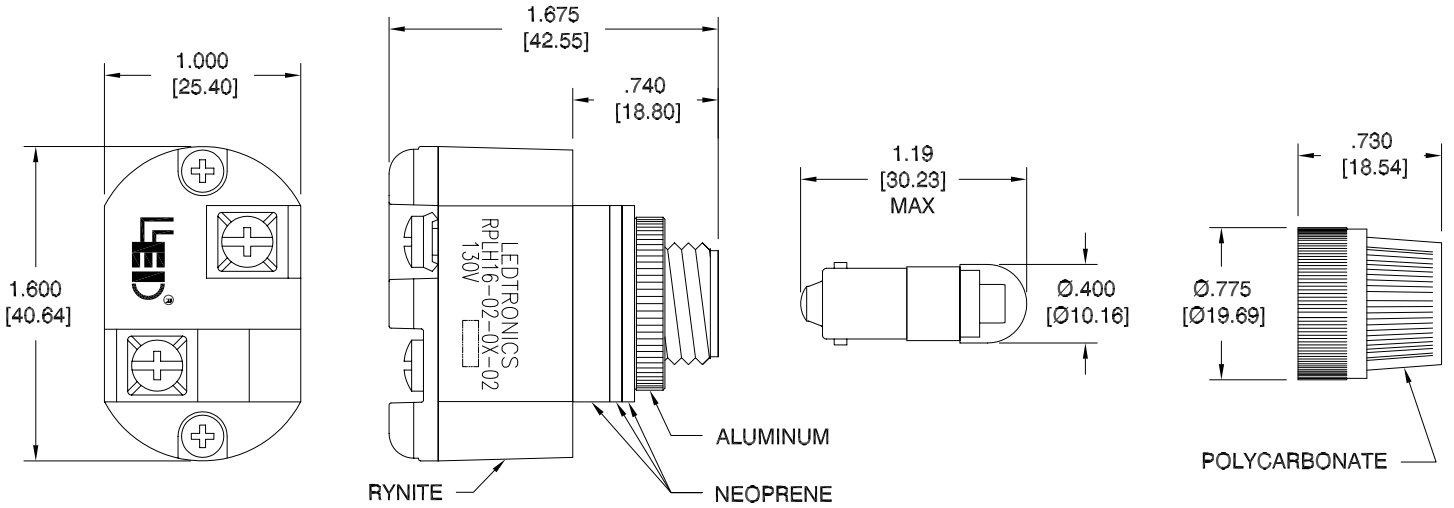

RPLH16-02-0X-02X

- COMPARABLE TO UL 508
- NEMA 3, 4, 4X, 5, 6, 12

NOTES:

1. ALL DIMENSIONS ARE IN INCHES [MILLIMETERS].
2. MOUNTING HOLE SIZE: Ø5/8" [Ø16mm]
3. ACCEPTABLE OPERATION AT VOLTAGES: 50VAC/DC TO 140VAC/DC
3. WEIGHT: 0.075 lbs. / 1.2 oz.



ELECTRICAL / OPTICAL CHARACTERISTICS (Ta = 25°C)

RPLH16-02-01-02	130Vdc/120Vac	0.014 A	1.82 W	635	RED	RPLH16-02	RPLB-0201-28V	RPLL16-CRF
RPLH16-02-02-02	130Vdc/120Vac	0.014 A	1.82 W	610	AMBER	RPLH16-02	RPLB-0203-28V	RPLL16-CAF
RPLH16-02-03-02	130Vdc/120Vac	0.014 A	1.82 W	595	YELLOW	RPLH16-02	RPLB-0204-28V	RPLL16-CYF
RPLH16-02-04-02	130Vdc/120Vac	0.014 A	1.82 W	519	GREEN	RPLH16-02	RPLB-0206-28V	RPLL16-CGF
RPLH16-02-05-02	130Vdc/120Vac	0.014 A	1.82 W	462	BLUE	RPLH16-02	RPLB-0208-28V	RPLL16-CBF
RPLH16-02-06-02	130Vdc/120Vac	0.014 A	1.82 W	8000K	WHITE	RPLH16-02	RPLB-0209-28V	RPLL16-TWF
RPLH16-02-07-02	130Vdc/120Vac	0.014 A	1.82 W	8000K	CLEAR	RPLH16-02	RPLB-0209-28V	RPLL16-CWF
LEDTRONICS PART NO.	INPUT VOLTAGE, V	CURRENT (A)	POWER (W)	λ P nm COLOR TEMP. (K)	COLOR EMITTED	LAMP HOLDER PART NO.	LED LAMP PART NO.	LENS PART NO.



-PROPRIETARY-
 This document contains Proprietary information of LEDTRONICS, INC. It may not be copied, used or disclosed for any purpose without the prior express written consent of LEDTRONICS, INC.
 .XXX ± .010 TOLERANCE PER ANSI-Y14.5
 .XX ± .025 (UNLESS OTHERWISE STATED)
 ANGLES ± 0°,30'
 FRACT. ± 1/32

TITLE RPLH16-02-0X-02					
DWG NO H1602001-INT		SCALE 1:1		SHEET 1 OF 1	
DATE 02-28-11		MFG LD 08-09-17		R&D LUV 08-09-17	
CODE IDENT NO. 8Z410	DWG BY GP 02-28-11	CHK BY	QA EE 08-09-17	MFG LD 08-09-17	R&D LUV 08-09-17