

LTR	REVISION	DATE	APPD
C	012721-GP02: REMOVED NOTATIONS	01-27-21	GP

LAMP HOLDER SERIES - RPLH30-02

LED LAMP SERIES - RPLB-020X

LENS - RPLL30-CXF

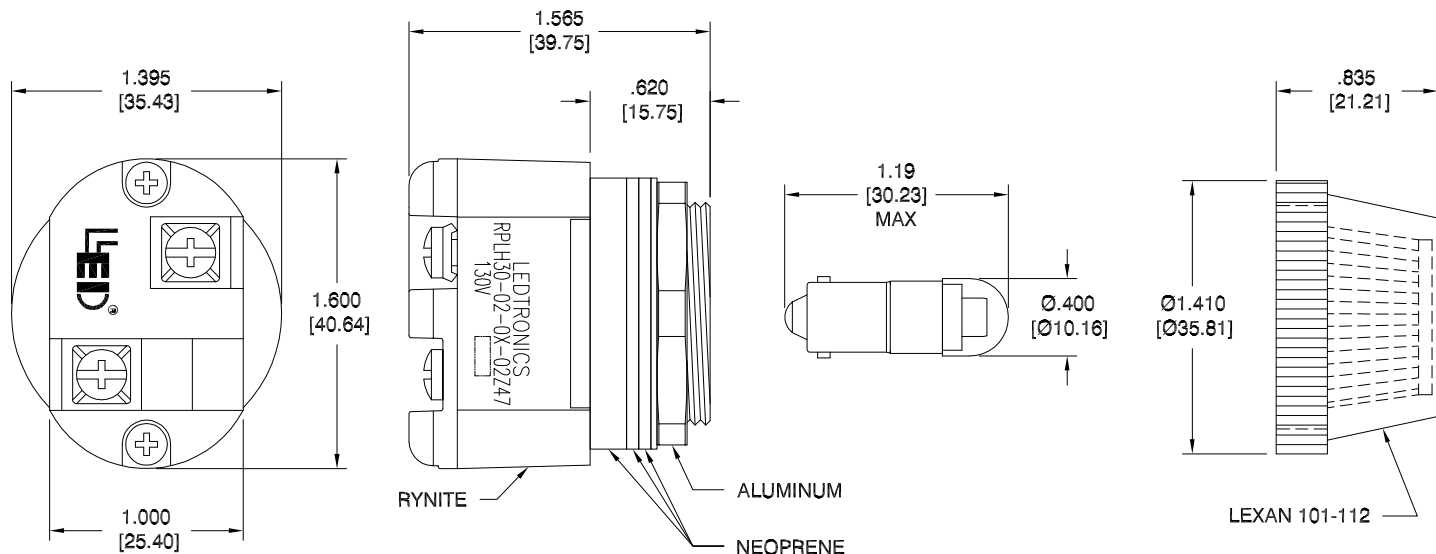

PLATING ZINC, YELLOW CHROMATE SCREW  
(CENTER BULB CONTACT)

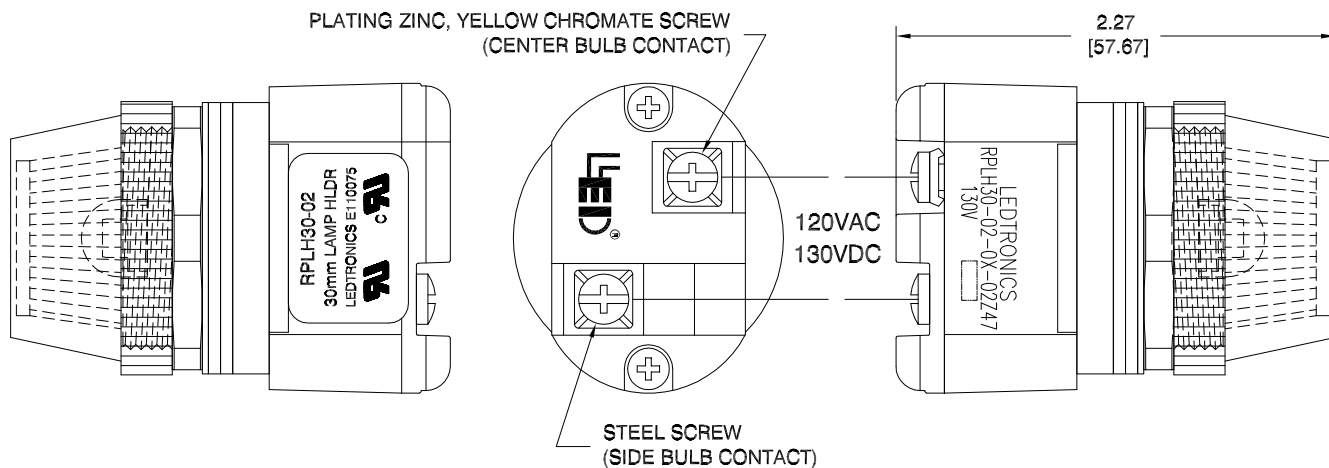

RPLH30-02-0X-02Z47

NOTES:

1. ALL DIMENSIONS ARE IN INCHES [MILLIMETERS].
2. MOUNTING HOLE SIZE: Ø19/16" [Ø30mm]
3. WEIGHT: 0.10 lbs. / 1.6 oz.



ELECTRICAL / OPTICAL CHARACTERISTICS (Ta = 25°C)

RPLH30-02-01-02Z47	130Vdc/120Vac	50Vdc Min.	0.010 A	1.3W	635	RED	RPLH30-02	RPLB-0201-130V47Z	RPLL30-CRF
RPLH30-02-02-02Z47	130Vdc/120Vac	50Vdc Min.	0.010 A	1.3W	610	AMBER	RPLH30-02	RPLB-0203-130V47Z	RPLL30-CAF
RPLH30-02-03-02Z47	130Vdc/120Vac	50Vdc Min.	0.010 A	1.3W	595	YELLOW	RPLH30-02	RPLB-0204-130V47Z	RPLL30-CYF
RPLH30-02-04-02Z47	130Vdc/120Vac	50Vdc Min.	0.010 A	1.3W	519	GREEN	RPLH30-02	RPLB-0206-130V47Z	RPLL30-CGF
RPLH30-02-05-02Z47	130Vdc/120Vac	50Vdc Min.	0.010 A	1.3W	462	BLUE	RPLH30-02	RPLB-0208-130V47Z	RPLL30-CBF
RPLH30-02-06-02Z47	130Vdc/120Vac	50Vdc Min.	0.010 A	1.3W	8000K	WHITE	RPLH30-02	RPLB-0209-130V47Z	RPLL30-TWF
LEDTRONICS PART NO.	INPUT VOLTAGE	TURN ON VOLTAGE	CURRENT (A) @130Vdc	POWER (W) @130Vdc	λ P nm COLOR TEMP. (K)	COLOR EMITTED	LAMP HOLDER PART NO.	LED LAMP PART NO.	LENS PART NO.

**LED**<sup>®</sup>  
LEDTRONICS,™ INC.  
23105 KASHIWA COURT  
TORRANCE, CA 90505

-PROPRIETARY-  
This document contains Proprietary information of LEDTRONICS,™ INC. It may not be copied, used or disclosed for any purpose without the prior express written consent of LEDTRONICS,™ INC.  
TOLERANCE PER ANSI-Y14.5 (UNLESS OTHERWISE STATED)  
.XXX ± .010  
.XX ± .025  
ANGLES ± 0°,30'  
FRACT. ± 1/32

TITLE <b>RPLH30-02-0X-02Z47</b>					
DWG NO H3002007-INT	SCALE 1:1	SHEET 1 OF 1	DATE 09-23-10		
CODE IDENT NO. 8Z410	DWG BY GP 09-23-10	CHK BY	QA SB 01-28-21	MFG LD 01-27-21	R&D LUV 01-27-21