

S70120RCM

70W S62

High Pressure Sodium

60Hz Reactor

Specification Sheet

Input Volts	120	120			
Regulation					
Line Volts	±5%	±5%			
Lamp Watts	±10%	±10%			
Power Factor (min)	90%	-			
Input Watts	82 W	82 W			
NOM. Open Circuit Voltage	120 V	120 V			
Line Current (Amps)					
Operating	0.70	1.55			
Open Circuit	1.30	-			
Starting	0.90	2.10			
Recommended Fuse (Amps)	4	6			
Lamp Dropout Voltage (Line)	90 V	90 V			
UL Temperature Ratings					
Insulation Class	H (180°C)	H (180°C)			
Temperature Code	A	A			
MIN. Starting Temperature	-40°F -40°C	-40°F -40°C			
CAPACITOR Specifications					
Microfarads	28 uf	-			
Volts (min.)	120 V	-			
60Hz Test Procedures					
High Potential Test 1 Minute	2000 V	2000 V			
High Potential Test 1 Second	2500 V	2500 V			
Secondary Open Ckt Voltage (V)	108 - 132	108 - 132			
Secondary Current Shorted (A)	1.90 - 2.35	1.90 - 2.35			
Input Operating Current (A)	0.60 - 0.80	1.40 - 1.75			
Input Open Circuit Current (A)	1.00 - 1.50	- - -			
Input Short Circuit Current (A)	0.60 - 1.10	1.90 - 2.35			
Core and Coil Specifications					
Dimension A	1.10 in	1.10 in			
Dimension B	2.25 in	2.25 in			
Weight	2.00 lbs	2.00 lbs			
Lead Lengths (inches)	12-14	12-14			
Coil Material (Pri. / Sec.):	Cu	Cu			

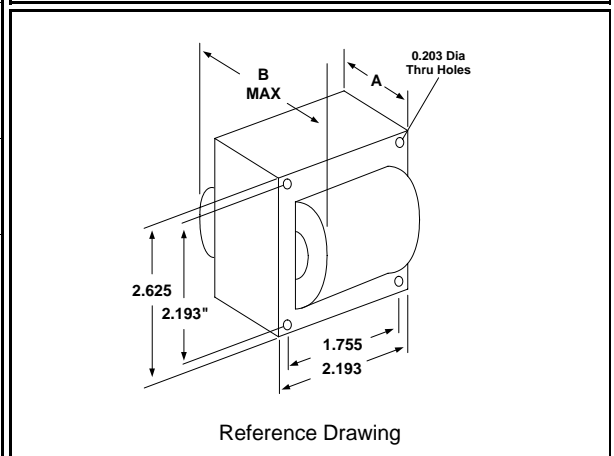
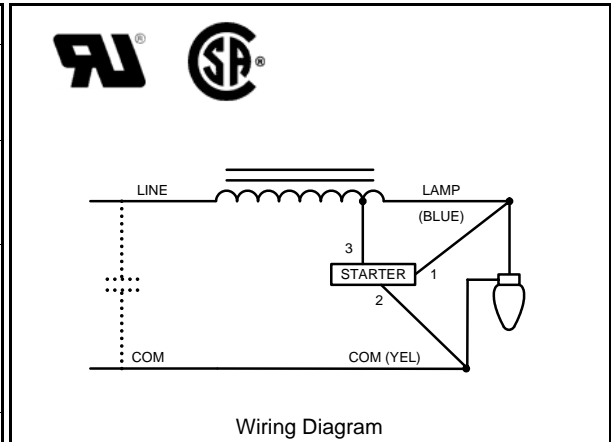

Capacitor: 005-1886-RMF	Ignitor: HPS150-3A
Max Case Temp: 100 °C	Max Case Temp 105 °C
Height: 2.25 in	BTL: 3 ft
Width / Diameter: 1.87 in	

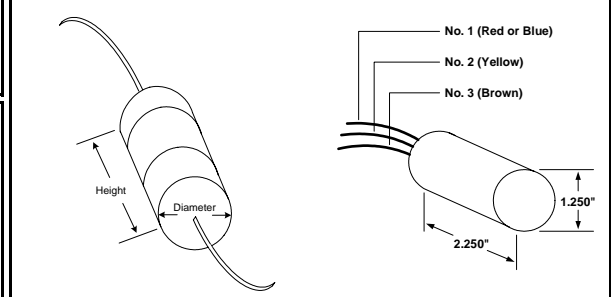

Oil Cap. - P/N R17058502 Consult Catalog for Specs.

Document #:	010-10717-03
Date:	11/17/2008
Status:	Production
Replaces Catalog #:	1233-142U

Data is based upon tests performed by Universal Lighting Technologies in a controlled environment and is representative of relative performance. Actual performance may vary depending on operating conditions. Specifications are subject to change without notice.