



LEDTRONICS
America's Premium Brand LED Company™

23105 Kashiwa Court, Torrance, CA 90505
Phone: (800) 579-4875 or (310) 534-1505 Fax: (310) 534-1424
E-mail: info@ledtronics.com
Website: <http://www.ledtronics.com>

SBX002T-300W-XPW-105A-MSP-A

Slim Shoebox Area Light

2- / 3-Step Dimming or 1-10Vdc Dimmable
w/ Microwave Sensor & Photocell, 300W
100~277Vac, Pure White (5000K) , Type V Lens
(with Slip Fitter Bracket)



DWG BY:

TS / HF
01-13-21

R&D:

LUV
10-14-22

MFG:

LD
10-17-22

QA:

LUV
10-14-22

REVISION LTR: PRELIMINARY (2)

ECR#: 083022-UF02

10-13-22

○ Features

| | |
|--------------------------|---------------------------------------|
| Operating Temperature | -4°F to +122°F |
| Storage Temperature | -22°F to +176°F |
| Housing Material / Color | Aluminum Alloy / Bronze |
| UL / cUL Listed | E330342 (SBX002T-300W-XPW-105A-XXX-X) |
| LED LM80 Report | Yes |
| LM79 Report | Yes |
| LED Quantity | 336 pcs. |
| Protection Rating | IP65 |
| Dimmable | Yes (1-10Vdc) |
| Lifespan | >50,000 hrs. |
| Warranty | 5 Years |
| Weight | 21.51 lbs. / 9.76 kg. |



○ Electro-Optical Characteristics

| Part Number | SBX002T-300W-XPW-105A-MSP-A |
|-----------------------|-----------------------------|
| Input Voltage (typ) | 100~277Vac |
| Tested @ (Voltage) | 120Vac |
| Power Consumption | 314.2 W |
| Current Consumption | 2.44 A |
| Efficacy: (Lm/W) | 137.07 |
| Lumens | 43,067.3 lm |
| Max Ft-Cd | 11,374 cd |
| Power Factor | 0.946 |
| CRI (Ra) | 70 |
| CCT | 5000K |
| Color | Pure White |
| Angle of illumination | 140° |

○ Dimensions

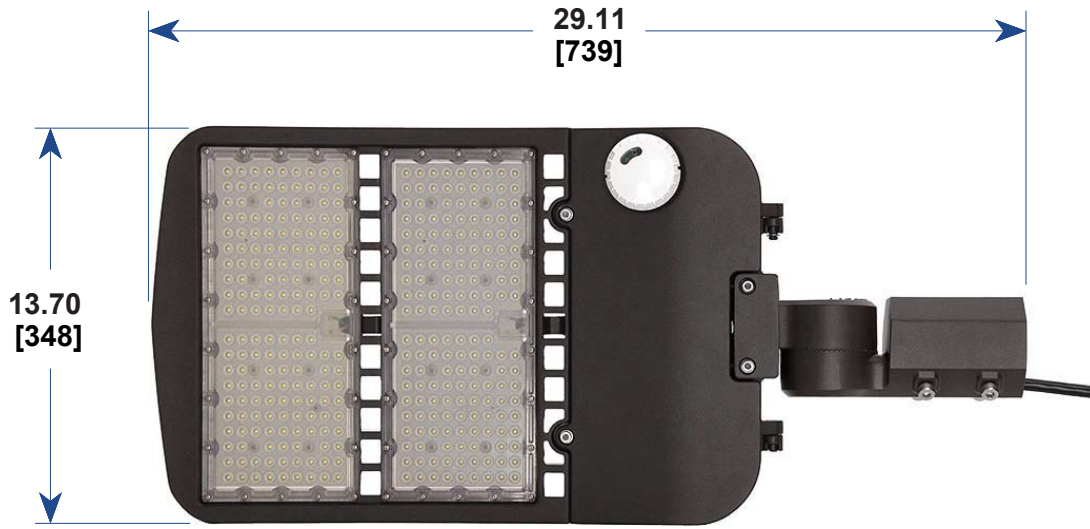

BOTTOM VIEW

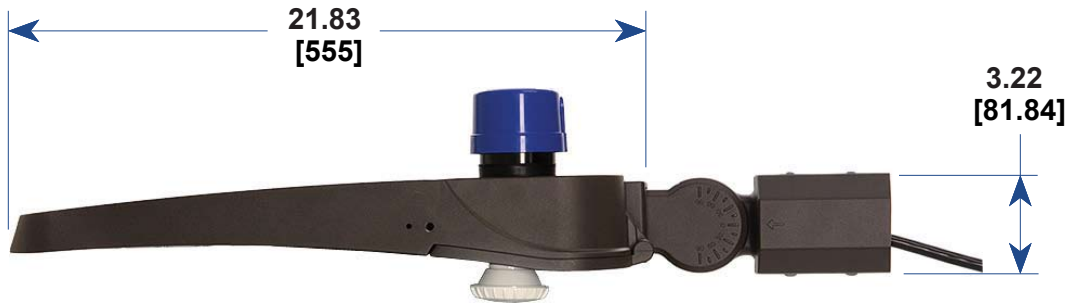

SIDE VIEW

Installation:
“-A-” Mounting Arm Adaptor
(Pole Ø60 mm)

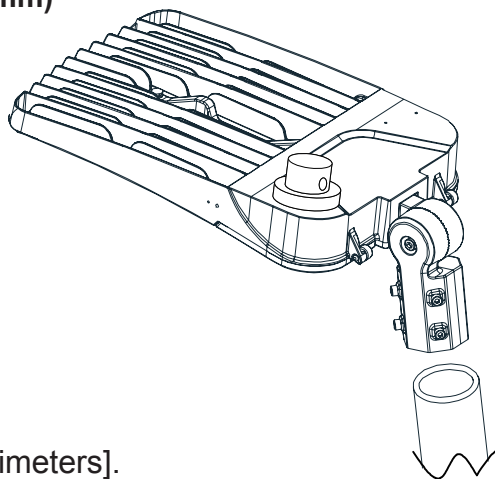

Tolerance:

XXX +/- .010

XX +/- .025

Note:

1. All Dimensions are in Inches [Millimeters].