

PROJECT NAME:	
DATE:	
CATALOG #:	
NOTES:	

SCRT Series

LED Petroleum Canopy Light

Product Highlights

- ▶ Ultra slim profile for low clearance applications
- ▶ Up to 155 lm/W efficacy
- ▶ 10 year limited warranty
- ▶ Quick, simple, one-person installation

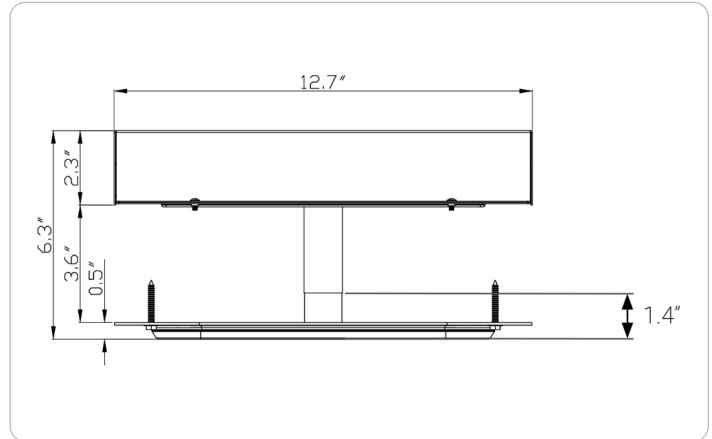

Ordering Guide

Example: SCRT-17L-50K-YY-UV-CLR-DM-WHT



PRODUCT FAMILY	LUMEN OUTPUT / WATTAGE	CCT	CUSTOMIZATION	INPUT VOLTAGE	LENS TYPE	CONTROLS	COLOR
SCRT Scottsdale Retrofit Light	17L- 17,133 lm / 104W	50K - 5000K	YY - YY is standard	UV - 120-277V	CLR - Clear	DM - 0-10V Dimming	WHT - White

Electrical

- ▶ Input Voltage: 120-277V 50/60Hz
- ▶ Power Factor: >0.9 at full load
- ▶ Total Harmonic Distortion: <20% full load
- ▶ Operating Temperature Range: -30°C to 40° C Ambient (-22°F to 104°F)

Electrical Load Table

CATALOG #	WATTAGE	CURRENT (A)			
		120V	208V	240V	277V
SCRT-17L	104W	0.87	0.52	0.45	0.40

Luminaire Data

CATALOG #	DLC PRODUCT ID	INPUT	POWER	LUMENS	CCT	CRI	PF
SCRT-17L-50K-YY-UV-CLR-DM-WHT	S-T5NYXM	120-277V 50/60Hz	104W	17,133 lm	5000K	≥ 70	≥ 0.9

Lumen Maintenance

PROJECTED LUMEN MAINTENANCE					
OPERATING HOURS	0	25,000	50,000	75,000	100,000
LUMEN MAINTENANCE FACTOR	1	0.95	0.90	0.86	0.81
* Projected LM values based on extrapolated LM-80 performance data testing and TM-21 calculations					

Construction and Materials

- ▶ Housing is constructed from sheet metal aluminum
- ▶ Power supply enclosure constructed from sheet metal aluminum
- ▶ Lens construction is a single piece of clear UV resistant polycarbonate
- ▶ Luminaire's construction contains zero mercury
- ▶ Fasteners are stainless-steel and will not rust or create rust-streaks

Regulatory and Voluntary Qualifications

- ▶ UL certified to UL 1598 both US and Canada
- ▶ DesignLightsConsortium® (DLC) Premium qualified product. Not all versions of this product may be DLC qualified. Please check the DLC Qualified Products List at www.designlights.org/QPL to confirm which versions are qualified.
- ▶ Rated for Wet location
- ▶ IP66 Rated

Warranty and Lifetime

- ▶ The SCRT Series carries a 10-year limited warranty. Contact Jarvis representative for details.
- ▶ Projected LED lifetime exceeds 100,000 hours under most operating conditions. Lifetime projections are calculated using data including LM-79, LM-80 and TM-21 calculations. Contact Jarvis representative for details.

Zonal Lumen Summary

ZONE	LUMENS	% LUMINAIRE
Low (0-30°)	4,893.80	28.60%
Medium (30-60°)	9,284.60	54.17%
High (60-80°)	2,748.00	16.03%
Very High (80-90°)	154.10	0.90%
Uplight (90-180°)	58.40	0.30%
Total Flux	17,139.10	100%

Installation

- ▶ SCRT Series installs into a standard gas station canopy deck pan using 4 self-drilling screws and a center mounting hole for wiring connections to the provided power supply box on the topside of the canopy. Installs in a 12" or 16" deck pan.
- ▶ For detailed installation instructions, videos, or additional information related to retrofit applications, please contact a Jarvis Representative.

Photometrics

Photometric information, including LM-79 reports and .IES files are available for most models at www.jarvislighting.com. Site photometrics and lighting layouts are available. Contact a Jarvis representative.

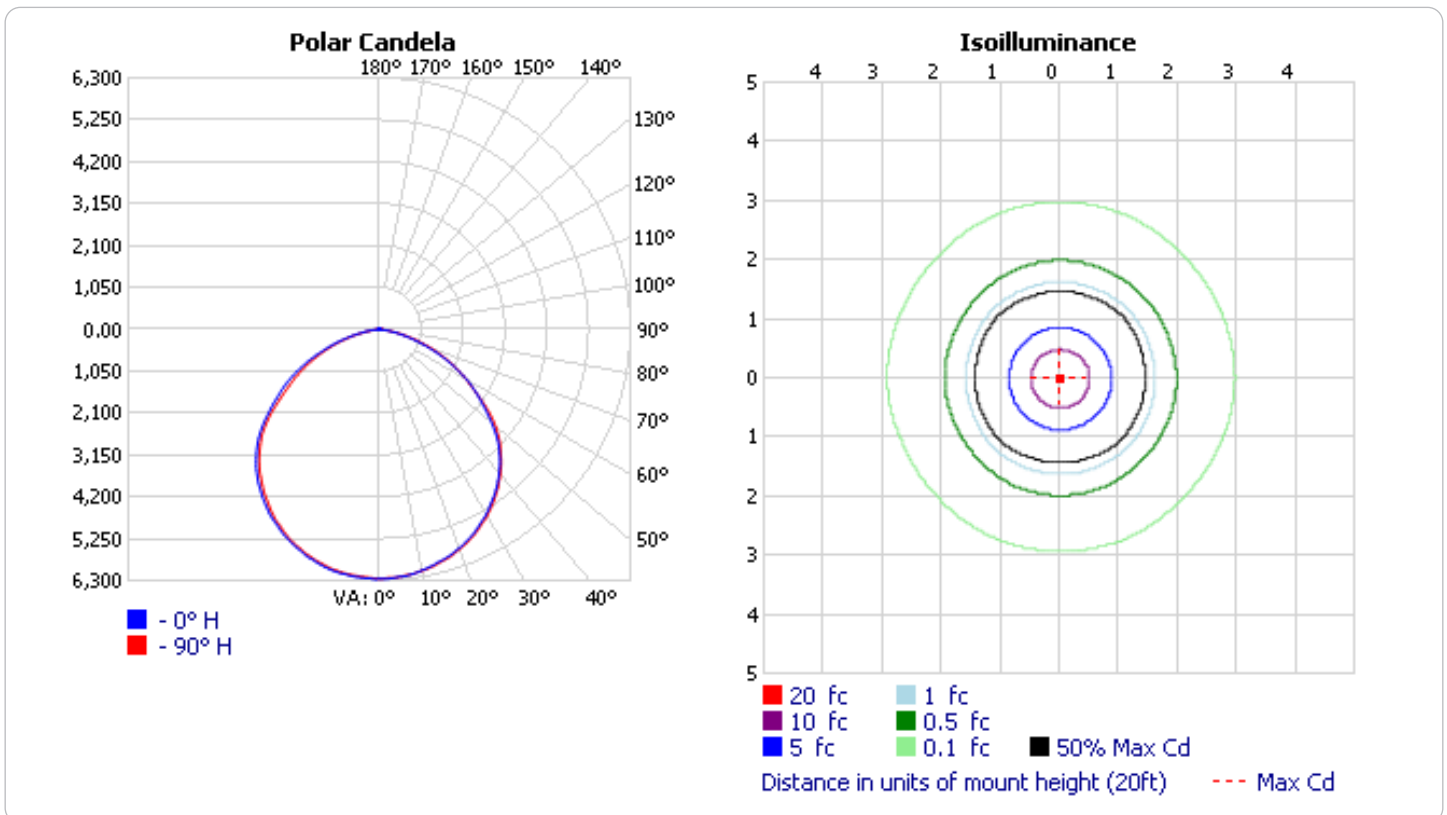

Additional Luminaire Photos

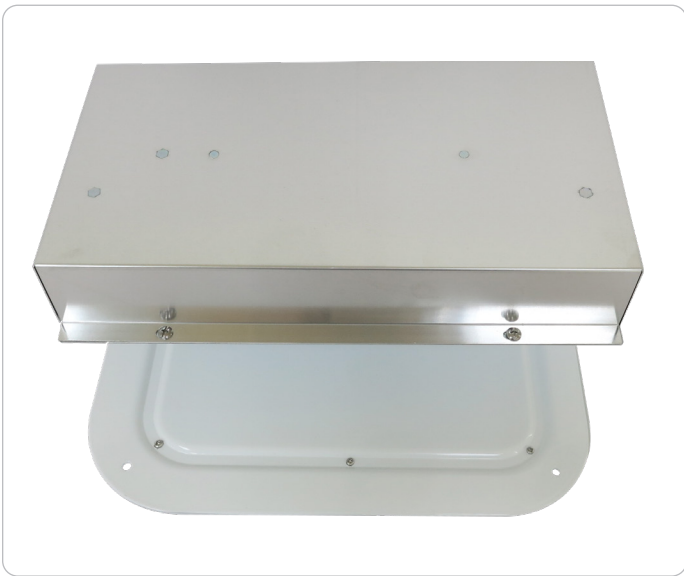

Dimensions

HOUSING & DRIVER BOX

