

SubstiTUBE® Advanced – ST8-HA5

Datasheet



Innovative LED-lamp, easy and safe to use in CCG installations as direct retrofit. Energy saving potential of up to 57% by replacing 1.5 m T8 fluorescent tubes. Instant 100% light without flickering. No mercury.

Applicable in warehouses, cold storage, supply rooms, corridors, industry, stairways, garages, indirect illumination etc; for applications with high operating hours.

Technical operating data

Product	Color	Colortemp. [K]	Lum. Flux [lm]	Voltage [V] / Frequency [Hz] / Input current [A]	Power [W]	Radiance-Angle [°]
ST8-HA5-340-865	Cool Daylight	6500 K	3400	230 V*		
ST8-HA5-340-840	Cool White	4000 K	3400	200 - 240 V / 50 / 60 Hz / 0.01 A	28 W	150°
ST8-HA5-306-830	Warm White	3000 K	3060			

All Data are related to the entire lamp. Due to the special conditions of the manufacturing processes of LED the typical data of technical parameters can only reflect statistical figures and do not necessarily correspond to the actual parameters of each single product which could differ from the typical data.

* Rated voltage

Technical Features

- LED lamp in T8 shape with G13 socket
- Length excl. pins: 1500 mm
- Weight: 400g
- For operation at magnetic ballast
- Direct Retrofit for CCG luminaires; replacement of lamp and included starter
- No rewiring necessary at CCG
- Extremely robust due to polycarbonate body
- Fully integrated ECG complies to relevant standards
- Powerfactor > 0.9
- Up to 50,000 h lifetime
- Switching cycles > 200.000
- Color Rendering Index (CRI) > 80
- Overpower, overheat and short circuit protected
- High color homogeneity
- RoHS-conformity, no mercury
- Not for operation with ECG, not dimmable
- Energy Efficiency Class: A+

Minimum / Maximum ratings

	Operating temperature T_c	Storage temperature T_s	Ambient temperature T_a
ST8-HA5	-20° ... 75°C	-20° ... 80°C	-20° ... 45°C

Drawings

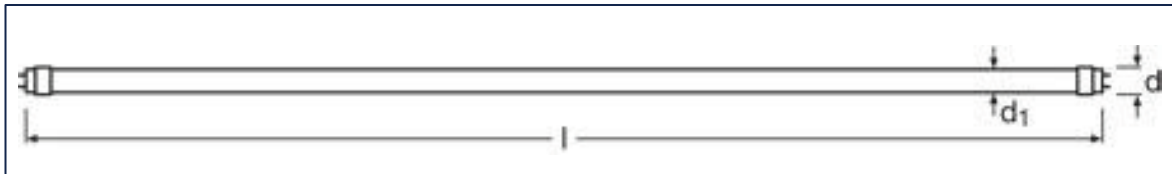

Product	l	d_1	d
ST8-HA5	1500 mm	26 mm	27,5 mm

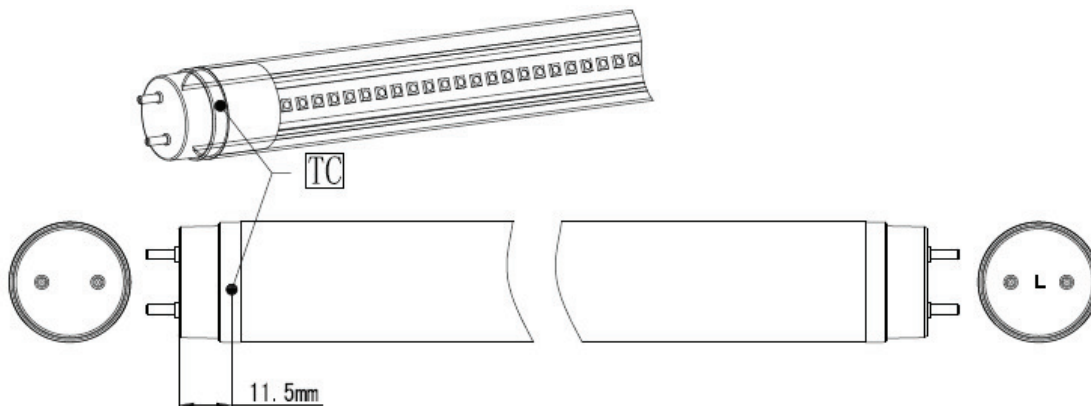

Safety and Application notes

- The SubstiTUBE® Advanced must not be damaged or operated in a damaged condition.
- When operating with CCG, the included „SubstiTUBE® Start“ has to be inserted as well. If the conventional starter is not replaced the SubstiTUBE® Advanced will start blinking. Switch off immediately, the SubstiTUBE® Advanced can be damaged!

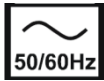

Lamp suitable for 50 Hz or 60 Hz operation



Lamp not suitable for high frequency operation



Lamp not suitable for emergency operation

- Do not use SubstiTUBE® Advanced in luminaires which do not have any starter or when the starter cannot be replaced.
- Not usable in luminaires with serial lamp connection i.e. more than one tube at one magnetic ballast (tandem circuitry).
- The SubstiTUBE® Advanced emits light only with a limited angle, not like a fluorescent tube with 360° output.
- Due to the characteristic light distribution of the SubstiTUBE® Advanced, the resulting luminaire light characteristic is likely to change. It is not guaranteed that e.g. standards for lighting at working places will be complied to after replacement. A photometric check of the installation is recommended.
- The effective energy savings depend on the efficiency of the luminaire setup to be replaced and should be considered individually in each case. Particularly magnetic ballast losses are reduced to ohmic losses and are normally only about 1 W.
-  The SubstiTUBE® Value is protected according to IP20. Applications with external risk of moisture and dust can be served with an adequately protected luminaire.
- SubstiTUBE® Advanced may also be driven directly on line voltage. In order to grant a safe operation mode please refer to the installation instructions for further information.

- Maximum amount of SubstiTUBE® Advanced on one circuit breaker

Circuit breaker 10 A (B type)	// CCG	//	53
	// CCG incl. comp. cap.	//	13
	// Direct mains	//	54
Circuit breaker 16 A (B type)	// CCG	//	86
	// CCG incl. comp. cap.	//	21
	// Direct mains	//	87

- Photobiological Safety of lamps and lamp systems according to IEC 62471.
Risk Group: Exempt

Installation Instructions for CCG

- Make sure that the supply voltage is disconnected.
- Carefully remove the fluorescent tube and starter according to the lamp holder type.
- Insert SubstiTUBE® Advanced and SubstiTUBE® Start properly.

Below an example for typical lamp holder types is described

- Turn the conventional lamp 90° degrees and take it out of the socket.
- Remove the conventional starter by turning it.
- Insert and latch the SubstiTUBE® Start into starter socket.
- Insert SubstiTUBE® Advanced into socket and locate into position by turning 90°.
- Check light emission direction.

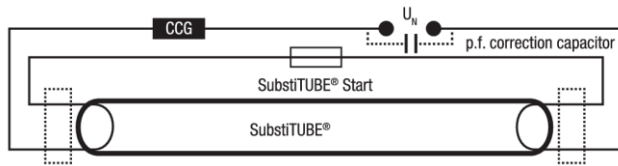
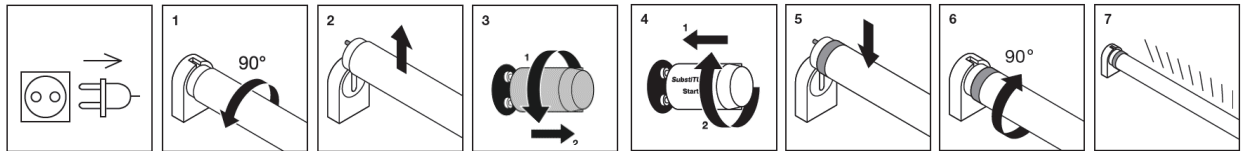

Circuit diagram of a retrofitted CCG luminaire

Ordering guide

Product name	Light color	EAN*	S-Unit**
ST8-HA5-340-865	Cool Daylight / 6500 K	4052899922181	
ST8-HA5-340-840	Cool White / 4000 K	4052899922174	25 x 1
ST8-HA5-306-830	Warm White / 3000 K	4052899922167	

* EAN: Ordering number per single module

** S-Unit: Lamps per shipping unit

Sales and Technical Support

OSRAM GmbH

Marcel-Breuer-Strasse 6
D - 80807 München Germany
www.osram.de
+49 (0)89 6213-0

Sales and technical support is given by the local OSRAM subsidiaries. On our world wide homepage all OSRAM subsidiaries are listed with complete address and phone numbers.

Further Information

➤ Downloads: Eulumdat /IES files, CE declaration

www.osram.com/SubstiTUBE