

EcoSystem® to 0–10 V Interface

The EcoSystem® to 0–10 V Interface provides a control gateway from an EcoSystem® link to a 0–10 V compatible lighting device, typically an LED driver.

It allows for individual addressing of the 0–10 V device, but provides only one-way communication from the controls to the 0–10 V device. This interface is suggested for single fixture control only. For multiple fixture control or for fixtures with multiple ballasts/drivers, please contact Lutron.

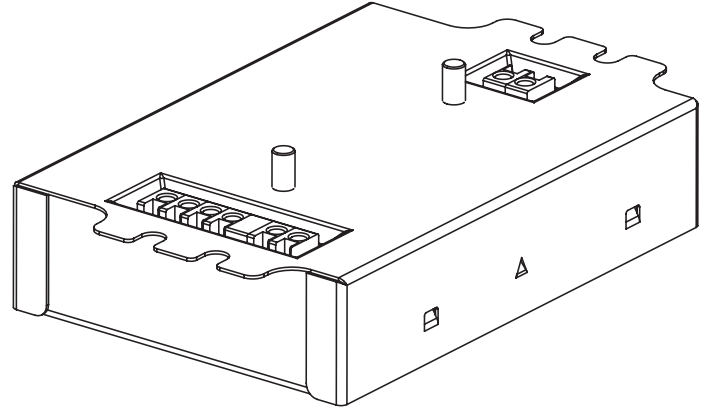

Features

- EcoSystem® Control Gear compatible: works with
 - GRAFIK Eye® QS control unit with EcoSystem®
 - Quantum® system
 - Energi Savr Node™ unit with EcoSystem®
 - PowPak® module with EcoSystem®
- Occupies one EcoSystem® unit address.
- Operates at 120 V~, 220/240V~, or 277 V~ input and provides one 120 V~, 220/240 V~, or 277 V~ switched output.
- Provides one 0-10 V low-voltage IEC PELV/NEC® Class 2 control output for devices compliant with IEC 60929 Annex E2 (“Control by DC voltage”).
- Switches up to 2 A of NEMA 410 compliant load.
- Complies with requirements for use in a compartment handling environmental air (plenum) per NEC® 2011 300.22(C)(3).
- Incorporates Lutron® Softswitch® technology, allowing a minimum of 1,000,000 relay cycles.

Job Name:

Model Numbers:

Job Number:

Specifications

Regulatory Approvals

- UL Listed
- cUL Listed

Power

- Operating voltage:
120 V~ 50/60 Hz
220/240 V~ 50/60 Hz
277 V~ 50/60 Hz
- Maximum input power (at any voltage):
≤ 1.0 W when output load is turned on
≤ 0.5 W when output load turned off (“standby”)
- Relay Output: 2 A of electronic load
- 5 drivers maximum per fixture.
- Input power to interface must not be switched.

Environment

- Ambient and contacting surface operating temperature:
–4 °F to 167 °F (–20 °C to 75 °C)
- 0% to 90% humidity, non-condensing.
- For indoor use only.

Power Wiring

- Interface is grounded by a mounting screw to the grounded fixture or a terminal connection.
- Terminals accept one 18 AWG to 16 AWG (1.0 mm² to 1.5 mm²) solid wire only.

EcoSystem® Link

- EcoSystem® Digital Link protected from line-voltage miswire.
- EcoSystem® Digital Link can be wired Class 1 or IEC PELV/NEC® Class 2 for maximum wiring flexibility.
- Terminals accept one 18 AWG to 16 AWG (1.0 mm² to 1.5 mm²) solid wire only.

Limitations

- Interface cannot detect or report LED driver failure.
- Low-end light level and dimming performance is determined by specifications of driver being used.

0–10 V Control Output

- Current rating: 25 mA max (sink only)
- Compliant to IEC60929 Annex E2 (“Control by DC Voltage”).
- Maximum 0–10 V wire length: 10 ft (3 m) from interface to driver
- Class 1 or IEC PELV/NEC® Class 2 wiring allowed, isolated from line and EcoSystem® link.
- Terminals accept one 18 AWG to 16 AWG (1.0 mm² to 1.5 mm²) solid wire only.
- Voltage Range:
Off: ≤ 0.5 V
Low end: 1 V
High end: 10 V
- Linear dimming curve:

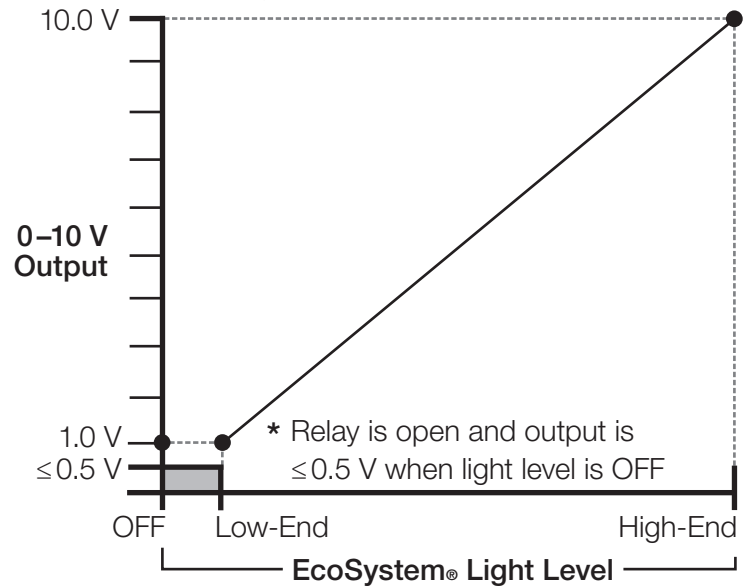

Job Name:

Model Numbers:

Job Number:

Wire Locations

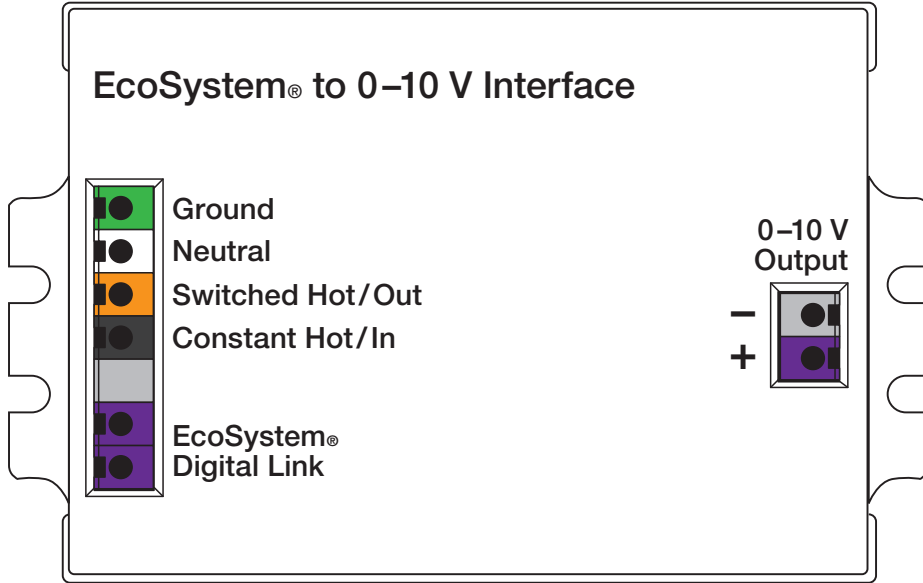

Wiring Diagram

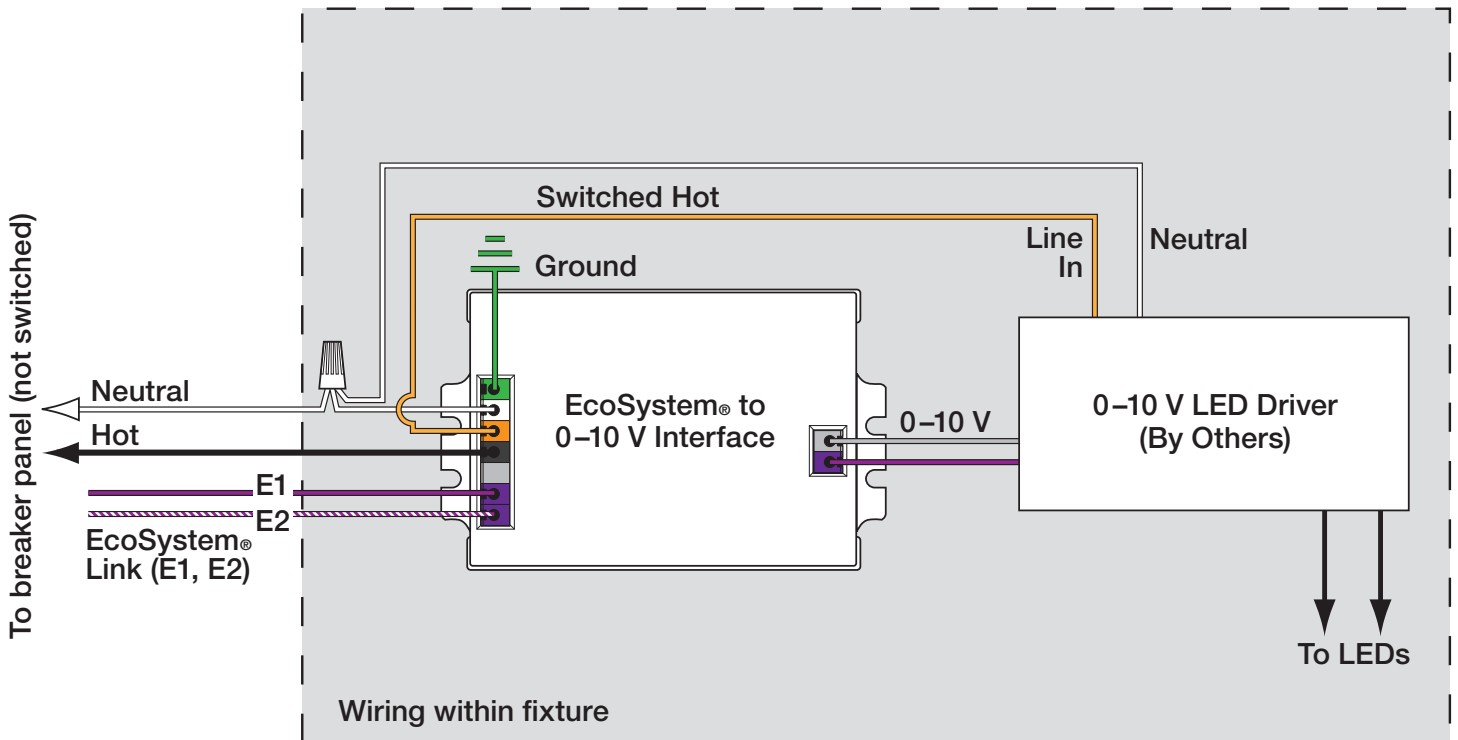

Job Name:	Model Numbers:
Job Number:	

Mounting Dimensions

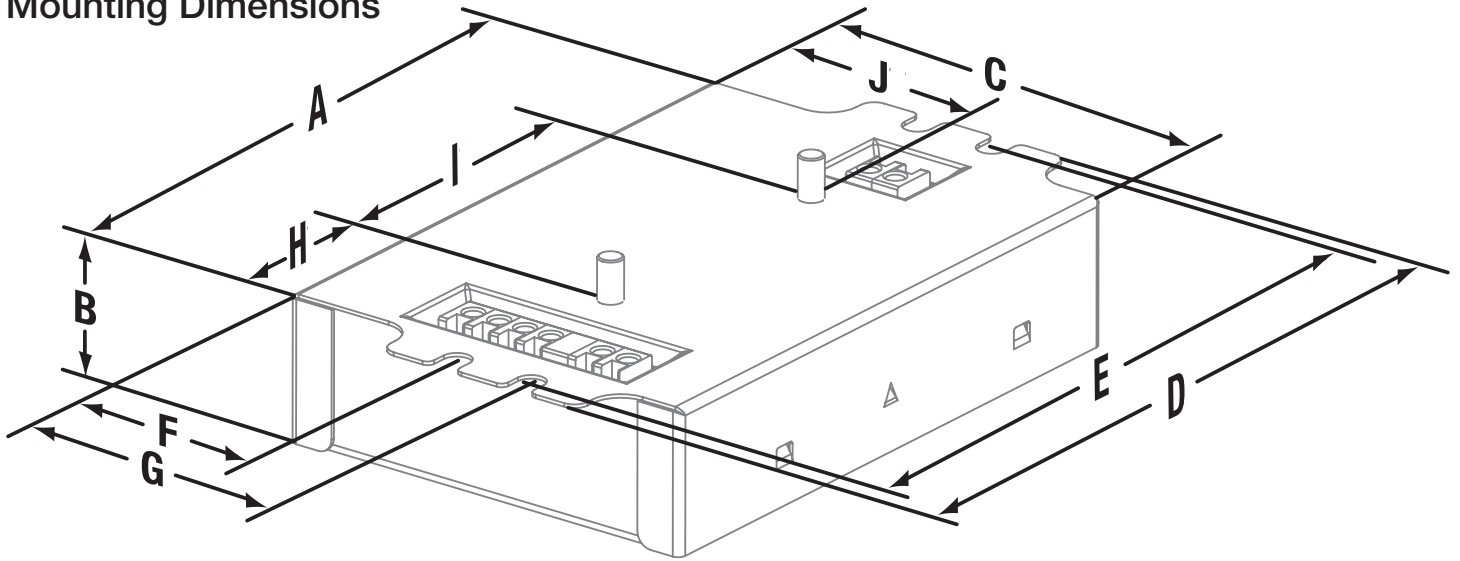

Connector Location Dimensions

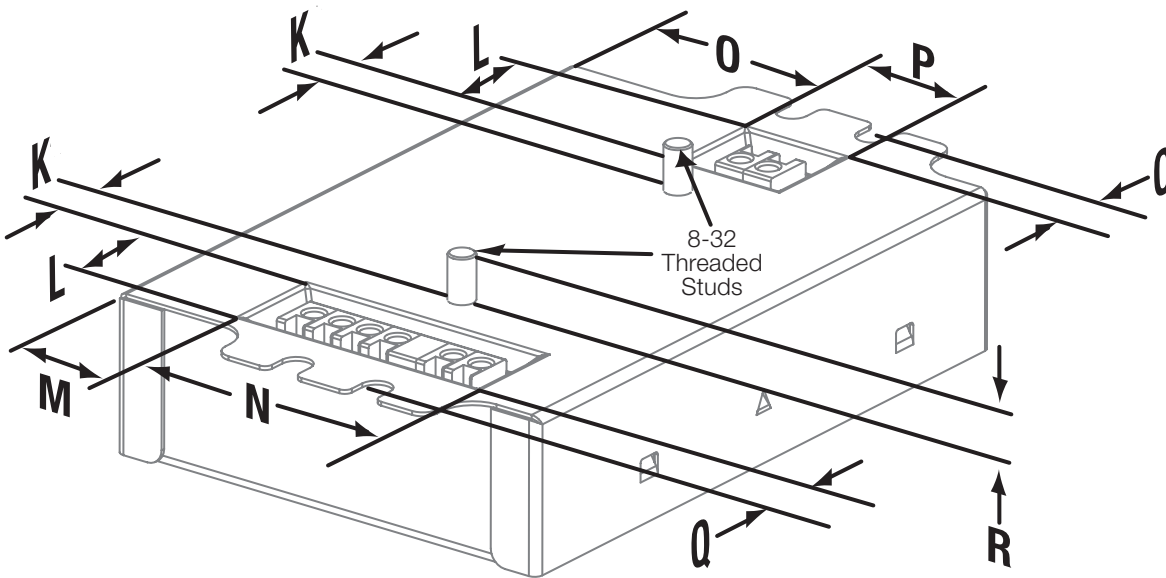

A	4.20 in (107 mm)	F	1.42 in (36 mm)	L	0.65 in (16.5 mm)	R	0.29 in (7 mm)
B	1.00 in (25 mm)	G	1.99 in (51 mm)	M	0.75 in (19 mm)		
C	3.00 in (76 mm)	H	1.11 in (28 mm)	N	1.73 in (44 mm)		
D	4.90 in (124 mm)	I	2.00 in (51 mm)	O	1.33 in (34 mm)		
E	4.60 in (117 mm) (mounting center)	J	1.60 in (41 mm)	P	0.74 in (19 mm)		
		K	0.33 in (8.3 mm)	Q	0.32 in (8 mm)		

Job Name:	Model Numbers:
Job Number:	

EcoSystem® to 0–10 V Interface Wiring Diagram:

EcoSystem® Digital Link Overview

- The EcoSystem® digital link wiring (E1 and E2) connects the interfaces together with other EcoSystem® devices to form a lighting control system.
- Each EcoSystem® digital link supports up to 64 EcoSystem® devices, 64 occupant sensors, 16 daylight sensors, and 64 wallstations or IR receivers.
- Sensors do not directly connect to EcoSystem® 0–10 V Interfaces.
- E1 and E2 (EcoSystem® digital link wires) are polarity insensitive and can be wired in any topology.
- An Energi Savr Node™ unit with EcoSystem®, PowPak® module with EcoSystem®, GRAFIK Eye® QS control unit with EcoSystem®, or a Quantum® system provides power for the EcoSystem® digital link and supports system programming.
- All EcoSystem® digital link programming is completed by utilizing a programming device appropriate for the control system being used.
- For complete information, see EcoSystem® Design and Application guide (Lutron® P/N 367-1533).

EcoSystem® Digital Link Wiring

- EcoSystem® digital link terminals only accept one solid wire per terminal from 18 AWG to 16 AWG (1.0 mm² to 1.5 mm²).
- Make sure that the supply breaker to the interface and EcoSystem® digital link power supply is OFF when wiring.
- Connect the two conductors to the two driver terminals E1 and E2.
- Using two different colors for E1 and E2 will reduce confusion when wiring several devices together.
- The EcoSystem® digital link may be wired Class 1 or IEC PELV/NEC® Class 2. Consult applicable electrical codes for proper wiring practices.

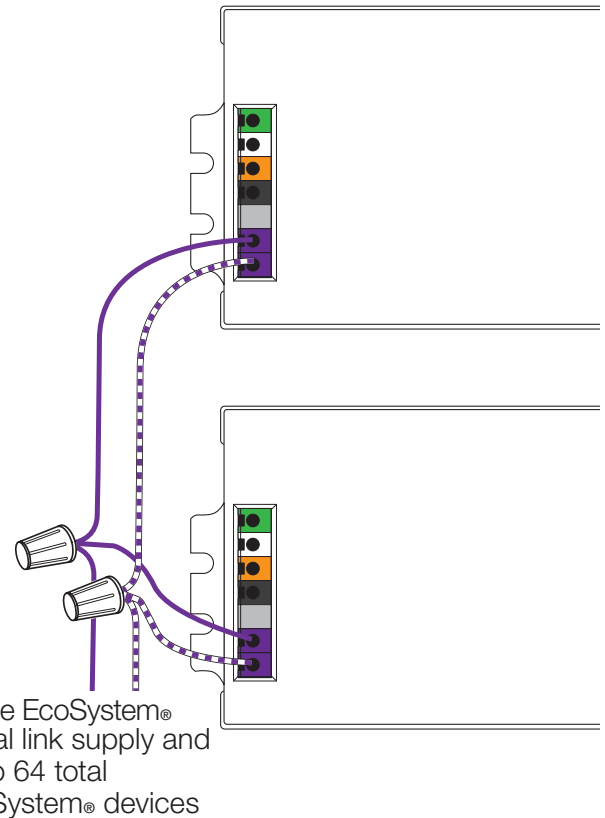

Notes

- The EcoSystem® digital link supply does not have to be located at the end of the digital link.
- E1 and E2 wires are not polarity sensitive.
- EcoSystem® digital link length is limited by the wire gauge used for E1 and E2 as follows:

Wire Gauge	Digital Link Length (max)
12 AWG	2200 ft
14 AWG	1400 ft
16 AWG	900 ft
18 AWG	550 ft

Wire Size	Digital Link Length (max)
4.0 mm ²	828 m
2.5 mm ²	517 m
1.5 mm ²	310 m
1.0 mm ²	207 m
0.75 mm ²	155 m

Job Name:

Model Numbers:

Job Number: