

# 100W S54

High Pressure Sodium

V90D1333

60 Hz HX-HPF

Input Volts	120	208	240	277
Line Current ( Amps )				
Operating	1.10	0.60	0.55	0.45
Open Circuit	2.10	1.20	1.05	0.90
Starting	0.90	0.55	0.45	0.40
Regulation				
Line Volts	±5%	±5%	±5%	±5%
Lamp Watts	±10%	±10%	±10%	±10%
UL Temperature Ratings				
Insulation Class	H	H	H	H
Coil Temperature Code	A	A	A	A
Benchtop Coil Rise				
Input Watts	126 W	126 W	126 W	126 W
NOM. Open Circuit Voltage	130	130	130	130
Power Factor	90%	90%	90%	90%
Current Crest Factor	1.50	1.50	1.50	1.50
Input Voltage At Lamp Dropout	90	160	180	210
MIN. Ambient Starting Temp.	-20°F -30°C	-20°F -30°C	-20°F -30°C	-20°F -30°C
60 HZ TEST PROCEDURES				
High Potential Test (Volts)				
1 Minute	2,000 V	2,000 V	2,000 V	2,000 V
1 Second	2,500 V	2,500 V	2,500 V	2,500 V
Open Circuit Voltage Test (V)	115 - 145	115 - 145	115 - 145	115 - 145
Short Circuit Current Test (A)				
Secondary Current				
Min	2.50	2.50	2.50	2.50
Max	2.80	2.80	2.80	2.80
Input Current				
Min	0.70	0.40	0.35	0.30
Max	1.00	0.60	0.50	0.45
Recommended Fuse (Amps)	6	3	3	3
CORE and COIL Specifications				
Dimension (A)	2.00 in	2.00 in	2.00 in	2.00 in
Dimension (B)	3.45 in	3.45 in	3.45 in	3.45 in
Weight (lbs.)	5.9 lb's	5.9 lb's	5.9 lb's	5.9 lb's
Lead Lengths	12 "	12 "	12 "	12 "
CAPACITOR Specifications				
Microfarads	10.0 uf	10.0 uf	10.0 uf	10.0 uf
Volts (min.)	280 V	280 V	280 V	280 V

**3X4 CORE - HX, CWA & CWI UNITS**

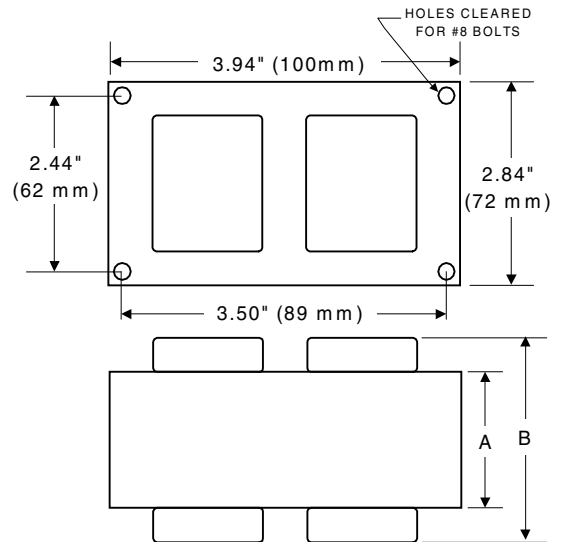

**Capacitor: ACG308**

**Ignitor: BVS-006-A**

Temp Rating: 100 °C  
 Height: 2.72 in  
 Dia/Oval Dim 1.48 in

Temp: 105 °C  
 BTL: 5 ft

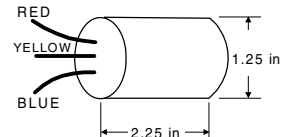
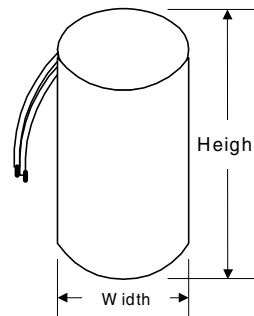

Plastic Dry Film Capacitor

Ordering Information Add Suffix for options

- C - With Capacitor
- K - With Capacitor and Bracket Kit
- B - With Welded Bracket no cap

Data is based upon tests performed by Venture Lighting in a controlled environment and is representative of relative performance. Actual performance can vary depending on operating conditions. Specifications are subject to change without notice

5/21/01

Production

