

BALLAST SPECIFICATION

250W M58

Metal Halide

V90D6211

60 Hz CWA

Input Volts	120	208	240	277
Line Current (Amps)				
Operating	2.60	1.45	1.30	1.10
Open Circuit	1.90	1.00	0.95	0.80
Starting	2.00	1.20	1.00	0.85
Recommended Fuse (Amps)	8	5	5	3
Regulation				
Line Volts	±10%	±10%	±10%	±10%
Lamp Watts	±7%	±7%	±7%	±7%
Temperature Ratings				
Insulation Class	180 (H)	180 (H)	180 (H)	180 (H)
Coil Temperature Code	B	A	C	B
Benchtop Coil Rise	76.0	74.4	82.9	79.5
Power Factor (Min)	90%	90%	90%	90%
Input Watts	291 W	291 W	291 W	291 W
Efficiency				
NOM. Open Circuit Voltage	305	305	305	305
Input Voltage At Lamp Dropout	65	115	130	150
Min Ambient Starting Temp	-20°F/-30°C	-20°F/-30°C	-20°F/-30°C	-20°F/-30°C
60 HZ TEST PROCEDURES				
High Potential Test (Volts)				
1 Minute	1,600 V	1,600 V	1,600 V	1,600 V
1 Second	2,000 V	2,000 V	2,000 V	2,000 V
Open Circuit Voltage Test (V)	275 - 335	275 - 335	275 - 335	275 - 335
Short Circuit Current Test (A)				
Secondary Current				
Min	2.20	2.20	2.20	2.20
Max	2.70	2.70	2.70	2.70
Input Current				
Min	1.60	0.90	0.80	0.70
Max	2.50	1.40	1.25	1.10
CORE and COIL Specifications				
Dimension (A)	2.80 in	2.80 in	2.80 in	2.80 in
Dimension (B)	4.20 in	4.20 in	4.20 in	4.20 in
Weight	8.5 lb's	8.5 lb's	8.5 lb's	8.5 lb's
Lead Lengths	12 "	12 "	12 "	12 "
Capacitor Requirement				
Microfarads	15.0 uf	15.0 uf	15.0 uf	15.0 uf
Volts (Min)	360 V	360 V	360 V	360 V

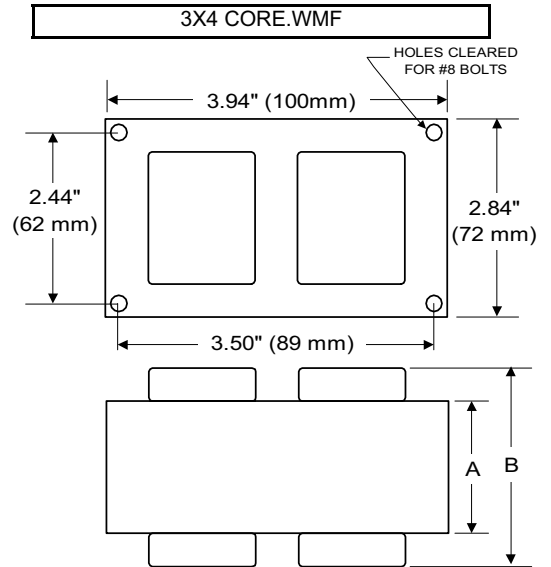

Capacitor: ACB2770V / ACG277	Ignitor: None
------------------------------	---------------

Microfarads:	15.0 uf	15.0 uf
Volts (Max):	400 V	400 V
Case Temp (Max)	100 °C	100 °C
Height (Max):	2.75 in	3.68 in
Dia (Max):	1.97 in	1.80 in
Oval Width (Max):	2.97 in	

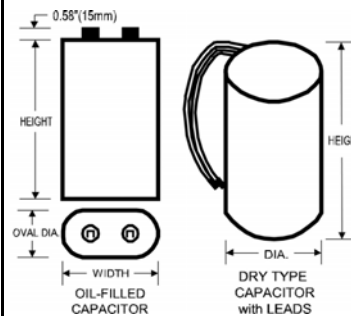

**This Ballast
Does Not
Require
An Ignitor**

Ordering Information Add Suffix for options

- C - With Oil-Filled Capacitor
- CB - With Oil-Filled Capacitor and Welded Bracket
- B - With Welded Bracket, no Capacitor
- K - Prewired, with Dry Capacitor and Bracket Kit
- D - With Dry Capacitor
- DB - With Dry Capacitor and Welded Bracket

RoHS compliant on all manufactured products after August 1, 2007

Data is based upon tests performed by Venture Lighting in a controlled environment and is representative of relative performance. Actual performance can vary depending on operating conditions. Specifications are subject to change without notice.

9/10/2008 Production Coil material: primary Cu and secondary Cu



RoHS

